

Room climate sensor HVAC Standard Art. no. 2006 ..



Table of contents

1	Information on the product	4
1.1	Product catalogue	4
1.2	Function	4
1.3	Device components	6
1.3.1	Front view	6
1.3.2	Rear view	7
1.3.3	Icons of the operating element	8
1.3.4	Icons in the display	9
1.4	As-delivered state	10
1.5	Technical data	11
1.5.1	Product information in accordance with the Ecodesign Directive (ErP 2009/125/EC)	12
2	Safety instructions	14
3	Mounting and electrical connection	15
3.1	Installation position	15
3.2	Mounting and connecting the device	16
3.3	Dismantling	17
4	Commissioning	18
4.1	Safe-state mode	19
4.2	Master reset	19
5	Operation	21
5.1	Examples for operating various standard applications	22
6	Application programs	25
7	Scope of functions	26
8	General settings	27
8.1	Basic settings	27
9	Sensor	31
9.1	Room temperature	32
10	Operating functions	39
10.1	Operating lock	39
10.2	On/off function	42
11	FanCoil with controller	46
11.1	Heating control	46
11.1.1	General heating control	46

11.1.2	Operating mode and setpoints	68
11.1.3	Command value output and command value limit	94
11.1.4	Controller status	106
11.1.5	Boost function.....	112
11.1.6	Floor temperature monitoring.....	115
11.1.7	Setpoint temperature limit, cooling.....	117
11.1.8	Setpoint temperature increase, heating	122
11.1.9	Scenes	125
11.2	Ventilation control	132
11.2.1	Fan behaviour	139
12	Air conditioning/split unit.....	157
12.1	Setpoint shift	157
12.2	Operating mode switchover	159
12.3	Fan adjustment	160
13	Display.....	171
13.1	Display indicators	171
13.2	Display brightness.....	179
14	Heartbeat function	183

1 Information on the product

1.1 Product catalogue

Product name	Room climate sensor HVAC Standard
Art. no.	2006 ..
Use	Sensor
Design	FM (flush-mounted)

1.2 Function

General

The product can support energy-efficient, user-friendly and reliable control of ventilation and split-unit systems in modern hotel and building technology applications.

The product can support the precise monitoring and control of temperature, humidity and air quality and can thus contribute to an energy-efficient and comfortable indoor climate in buildings.

The structured and intuitive presentation of the display and control surfaces enables user-friendly operation without the need for instruction. At the same time, the device can support efficient control and monitoring of comfort functions in the room climate area, both in hotels and in general building applications.

Display

The device is used for the clear visualisation and control of room climate functions via an integrated display. The indicator is segment-based and provides the user with all relevant information to quickly and clearly record the current operating status.

Among other things, operating mode display, main and secondary display, humidity display are available. In addition, special statuses such as window status, operating lock, boost function, heating and cooling mode, ventilation control, automatic mode as well as ventilation and dehumidification are displayed. Even when switched off, the display ensures clear status feedback.

FanCoil with controller

The product is used for convenient and intuitive control of ventilation systems, for example in hotel environments. The user interface is intuitively designed and supports all essential ventilation control functions. When used with fan coil systems, the device displays and adjusts key operating parameters such as set and actual temperature, humidity, operating mode and heating or cooling status. It also allows the fan speed to be regulated (on, off, auto, stepped operation). The integrated heating control ensures self-sufficient operation. The control and feedback of the fan stages is carried out either via 1-byte or 1-bit objects. In addition, objects for manual control and feedback messages about the current operating mode and fan speed are available.

Air conditioning/split unit

The product can be used to control split unit air conditioners in buildings and offers intuitive operation for end users. The control system includes the adjustment of the target temperature. The operating mode can be switched via split unit objects (automatic, heating, cooling, ventilation, dehumidification, eco, boost) or fan coil objects (comfort, standby, night). It is also possible to set the fan speed (on, off, auto, stepped operation) and switch off the appliance.

Sensor

The device is used to record and transmit central room climate parameters to support precise and energy-efficient room temperature control. The integrated temperature sensor reliably measures and provides the local room temperature. Optionally, the temperature measurement can be supplemented via a receiving object to increase the accuracy of the measurement result.

ETS

The device is KNX Data Secure capable. KNX Data Secure offers protection against manipulation in building automation and can be configured in the ETS project. Detailed technical knowledge is a prerequisite. A device certificate, which is attached to the device, is required for safe commissioning. During mounting, it is recommended to remove the certificate from the device and to store it securely.

The device can be updated. Firmware can be easily updated with the Gira ETS Service App (additional software).

1.3 Device components

1.3.1 Front view

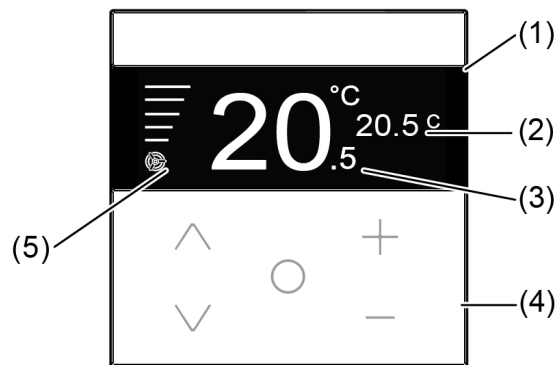

Figure 1: Front view

- (1) Display
- (2) Target temperature / humidity
- (3) Actual-temperature
- (4) Operating element (operating buttons 1 - 5)
- (5) Fan level/mode

1.3.2 Rear view

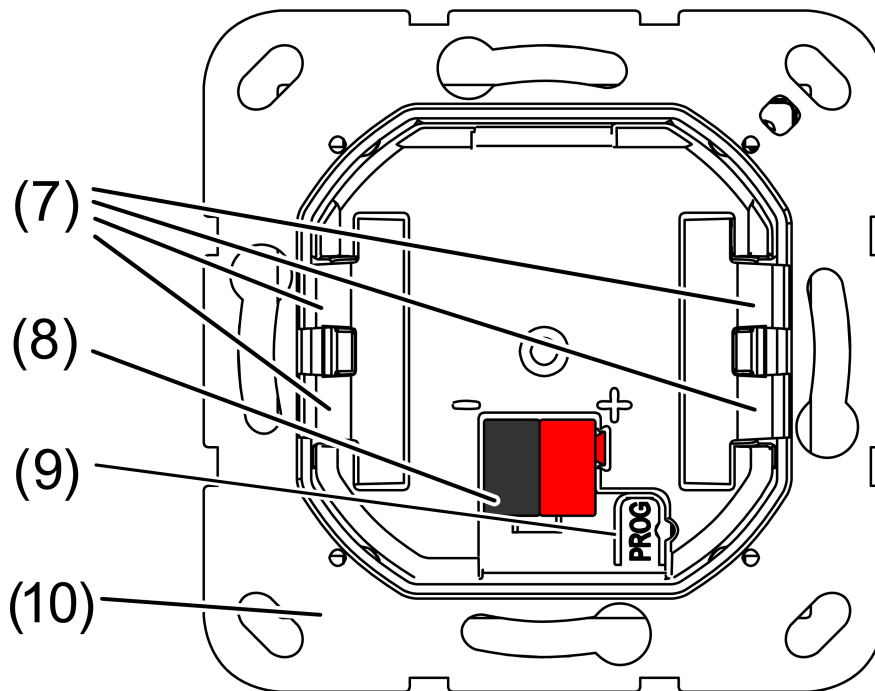

Figure 2: Rear view

- (7) Retaining clips for device fixation at the supporting frame
- (8) Device connection terminal, bus
- (9) Programming button with programming LED
- (10) Supporting frame

1.3.3 Icons of the operating element

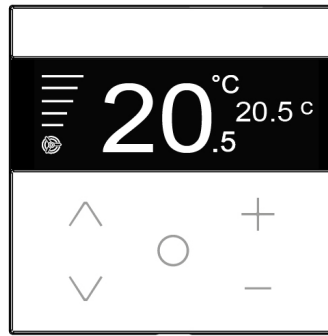

Figure 3: Icons of the operating element



Pressing the button leads to an increase in the setpoint value.



Pressing the button leads to a reduction in the setpoint value.



ON / OFF: The device is switched on/off with a long press of the button.

Change operating mode and display of measured values: A short press of the button switches between the operating modes and the display of measured values.



Pressing the button increases the fan speed.



Pressing the button reduces the fan speed.

1.3.4 Icons in the display

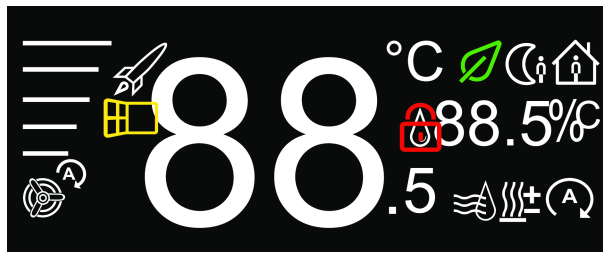















Figure 4: Icons in the display

	Comfort operating mode is active
	Reduction temperature operating mode is active
	Night setback operating mode is active
	Eco operating mode is active
	Operating lock is activated
	Air humidity
	Automatic mode is active.
	Heating/cooling
	Ventilation/dehumidification (only as device type "split unit control")
	The boost function is active
	Window status (open window was recognised)
	Ventilation operating mode is active
	Ventilation in automatic mode

1.4 As-delivered state

On delivery, the device only shows two "-" in the main segment of the display. All other segments of the display are hidden. The display backlight is set to 100 % brightness.

In the state as delivered, the device does not send any telegrams to the KNX bus. The application is also unloaded, which means that the device is in a neutral basic state.

This preconfigured delivery status remains unchanged until the device has been parameterised and configured for the specific project.

1.5 Technical data**Ambient conditions**

Ambient temperature	-5 ... +45 °C
Storage/transport temperature	-20 ... +70 °C
Relative humidity	5 ... 95% (no moisture condensation)
Protection class	III

Installation dimensions (see figure 5)

Construction height	A = 10 mm
Installation depth	B = 19 mm

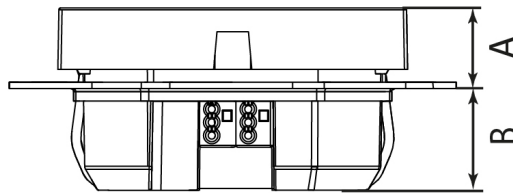

Figure 5: Installation dimensions

KNX

KNX medium	TP256
KNX commissioning mode	S mode
Rated voltage	DC 24 ... 30 V SELV
Current consumption KNX	8 ... 14 mA
Connection mode KNX	Standard device connection terminal
Connecting cable KNX	EIB-Y (St)Y 2x2x0.8

Information according to ErP 2009/125/EC

Electronic room temperature controller	yes
Power consumption	
– In networked standby mode	< 0.5 W
– In standby mode with information or status indication	yes
Control accuracy	yes (0.5 K)
This controller fulfils the following control functions	HP(1/2/3/0/0/0/8)

1.5.1 Product information in accordance with the Ecodesign Directive (ErP 2009/125/EC)

1.5.1.1 Ecodesign Table 6

Contact details: Gira Giersiepen GmbH & Co. KG, Dahlienstraße, 42477 Radevormwald, Germany			
Model identifier: Room climate sensor HVAC Standard, 2006 .. Room climate sensor HVAC Komfort, 2007 ..			
Specification	Icon	Value	Unit
Power consumption			
In the off state	P_0	-	W
In standby mode	P_{sm}	-	W
In idle state	P_{idle}	-	W
In networked standby mode	P_{nsm}	< 0.5	W
In standby mode with information or status display		yes	
Type			
Single-stage heat output, no room temperature control		no	
Two or more manual levels, no room temperature control		no	
Room thermostat with mechanical thermostat		no	
Electronic room temperature controller		yes	
Electronic room temperature controller with time-of-day control		no	
Electronic room temperature controller with weekday regulation		no	
Other control options			
Presence detection		yes	
Detection of open windows		yes	
Remote control option		yes	
Adaptive control of the start of heating		no	
Operating time limit		no	
Black ball sensor		no	
Self-learning function		no	
Control accuracy		yes (0.5 K)	

1.5.1.2 Ecodesign Table 7

Codes of the control functions

The format of the code is TC (f1/f2/f3/f4/f5/f6/f7/f8), where TC is the code for temperature control and f1 to f8 are the codes for the respective control functions, if available; otherwise "0" must be specified.

		(TC)*	Control functions							
			f1	f2	f3	f4	f5	f6	f7	f8
Type of temperature control	Single-stage heat output, no room temperature control	NC								
	Two or more manual levels, no room temperature control	TX								
	Room thermostat with mechanical thermostat	TM								
	Electronic room temperature controller	HP								
	Electronic room temperature controller with daytime control	TD								
	Electronic room thermostat with weekday control	TW								
Control functions	Presence detection		1							
	Detection of open windows			2						
	Remote control option				3					
	Adaptive control of the start of heating					4				
	Operating time limit						5			
	Black ball sensor							6		
	Self-learning function								7	
	Control accuracy with CA < 2 Kelvin and CSD < 2 Kelvin									8

* Temperature control code

2 Safety instructions



Electric devices may only be mounted and connected by electrically skilled persons.

To avoid potential damage, read and follow the following instructions:

Danger of electric shock. Comply with the regulations and standards that apply to SELV circuits during the installation and cable routing.



Touch-sensitive surfaces can be damaged. Do not operate the device with sharp or pointed objects.

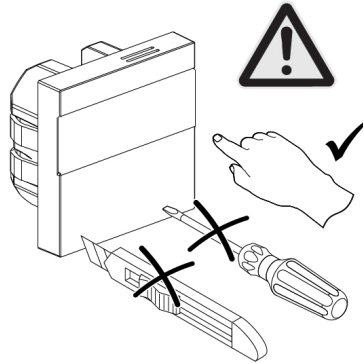

Figure 6: Damage to appliances due to sharp or pointed objects

3 Mounting and electrical connection



DANGER!

Danger of electrical shock when mains voltage 230 V or other external voltages are connected!

Electric shocks can be fatal.

Device may be destroyed.

Only connect potential-free push-buttons, switches or contacts.

3.1 Installation position

The device (see figure 7) is installed horizontally.

- i** When installing the appliance, read the TOP labelling at the top Mounting and connecting the device.

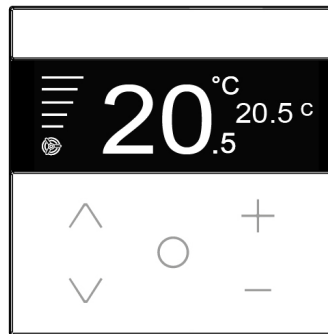

Figure 7: HVAC room climate sensor

3.2 Mounting and connecting the device

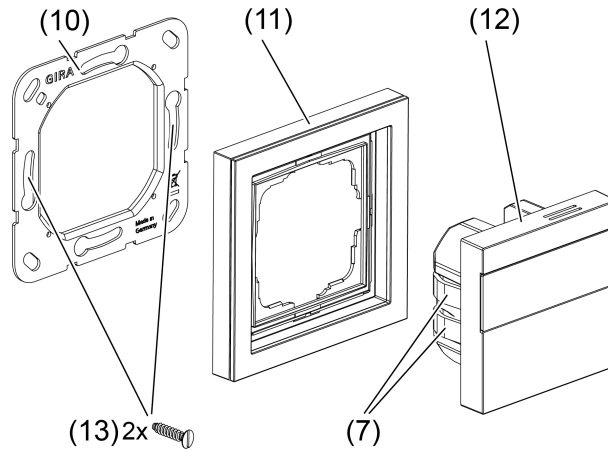

Figure 8: Mount device

- (7) Retaining clips for device fixation at the supporting frame
- (10) Supporting frame
- (11) Cover frame (accessory)
- (12) Device
- (13) Box screws

The device should be used in an air-tight appliance box. Otherwise temperature and humidity reading can be negatively influenced by draughts.

- Mounting in suitable appliance box. Observe cable routing and spacing.
- Mount supporting frame on an appliance box.

i Note the TOP marking.

i Use the enclosed box screws.

- Connect bus line with device connection terminal observing the correct polarity (red = +, black = -).
- In secure mode: Enter or scan the device certificate and add it to the project. A high resolution camera should be used to scan the QR code.

i The matching cover frame for the device must be ordered separately.

- Fit the cover frame flush. The cover frame is fixed by the device.
- Attach the device with cover frame onto the supporting frame.

The device can be put into operation.

i Make sure the that the retaining clips properly fit in the supporting frame.

The physical address is programmed in the next work step.

3.3 Dismantling

- Carefully pull the device forwards together with the cover frame.

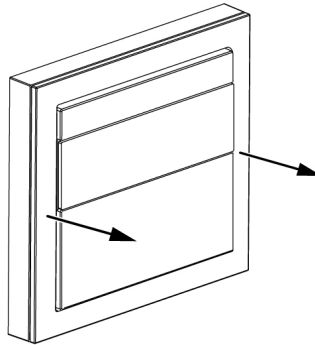

Figure 9: Dismantling the device

4 Commissioning

Programming the physical address and application program

i Project design and commissioning with ETS version 5.7.7 and higher or 6.3.0.

In secure operation (prerequisites):

- Secure commissioning has been activated in the ETS.
- Device certificate entered/scanned or added to the ETS project. A high resolution camera should be used to scan the QR code.
- Document all passwords and keep them safe.

The programming button is located on the back of the appliance (see chapter "Rear view" ▶ Page 7).

Precondition: The device is connected and ready for operation.

- Activating Programming mode: push the programming button.

The programming LED lights up red. Programming mode is activated.

- Programming the physical address.

The programming LED goes out. Physical address is programmed.

- Programming the application program.

The device is for use.

i The display can be switched off temporarily while the application program is being programmed. As soon as the programming process has been successfully completed, the device switches on.

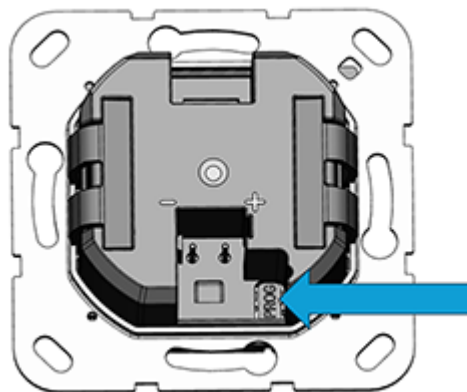

Figure 10: Programming button

4.1 Safe-state mode

The safe-state mode stops the execution of the loaded application program.

If the device does not work properly - for instance as a result of errors in the project design or during commissioning - the execution of the loaded application program can be halted by activating the safe-state mode. The device remains passive in safe-state mode, since the application program is not being executed (state of execution: terminated).

Only the system software of the device is still functional. ETS diagnosis functions and programming of the device are possible.

Activating safe-state mode

- Switch off the voltage.
- Press and hold down the programming button.
- Switch on voltage.

Safe-state mode is activated. The programming LED flashes slowly (approx. 1 Hz).

Release the programming button only after the programming LED starts flashing.

Deactivating safe-state mode

- Switch off the voltage or carry out ETS programming.

4.2 Master reset

The master reset restores the basic device settings (physical address 15.15.255, firmware remains in place). The device must then be recommissioned with the ETS.

- i** In secure operation: A master reset deactivates device security. The device can then be recommissioned with the device certificate.
- i** Devices can be reset to factory settings with the ETS Service App. This function uses the firmware contained in the device that was active at the time of delivery (delivery state). Restoring the factory settings causes the devices to lose their physical address and configuration.

If the device - for instance as a result of errors in the project design or during commissioning - does not work properly, the loaded application program can be deleted from the device by performing a master reset. The master reset resets the device to delivery state. Afterwards, the device can be put into operation again by programming the physical address and application program.

Performing a master reset

Precondition: The safe-state mode is activated.

- Press and hold down the programming button for > 5 seconds until the programming LED starts flashing quickly.
- Release the programming button.

The device performs a master reset. The programming LED is switched on.

The device restarts and is in delivery state.

5 Operation

- i** Touch-sensitive surfaces can be damaged. Do not operate the device with sharp or pointed objects.

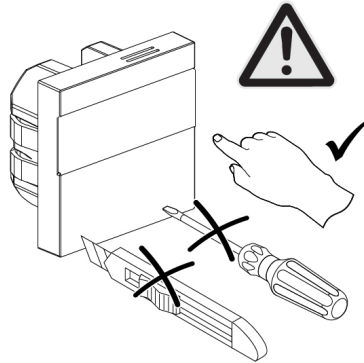

Figure 11: Damage to appliances due to sharp or pointed objects

The device is operated by pressing the buttons for a short, medium-long or long time, which depends on the specific functions configured.

Status	Min. length of time the button is pressed	Max. length of time the button is pressed
no keystroke recognised	0	≤ 50 ms
Brief pressing of a button	> 50 ms	≤1 s
Button press medium long	> 1 s	≤4 s
Pressing and holding a button	> 4 s	≤10 s

5.1 Examples for operating various standard applications

Increasing or decreasing the target temperature

- Short press(>50 ms) of the - or + button

With every brief press of a button the setpoint temperature changes by 0.5 °C. The set value is retained in manual mode; in automatic mode it is retained until the next switching time is reached.

If no operation is performed within a previously defined period of time (1 second) or if the O button is pressed briefly, the setpoint temperature is temporarily adopted. This is signalled by the device flashing twice.

In cooling mode, the – or + buttons cannot be used to change the setpoint temperature.

If the display is switched off, it is necessary to press the - or + button a second or further time before changing the setpoint.

- Medium-long press(>1 s) of the - or + button

Each time the button is pressed for a medium length of time, the setpoint temperature changes by 0.5 °C at a faster rate. The set value is retained in manual mode; in automatic mode it is retained until the next switching time is reached.

If no operation is performed within a previously defined period of time (1 second) or if the O button is pressed briefly, the setpoint temperature is temporarily adopted. This is signalled by the device flashing twice.

- Long press(>4 s) on the - or + button

In heating mode, the stored setpoint temperature is retrieved:
– = reduction temperature
+ = comfort temperature

-  During a detected temperature drop, changing the setpoint temperature is not possible.

Increasing or decreasing the ventilation level

- Short press(>50 ms) of the \wedge or \vee button

Each time the button is pressed briefly, the ventilation level is reduced or increased by one level (sequence: 0 - Auto - 1 - 2 - 3 - 4 - 5 - Auto). The set value is retained in manual mode; in automatic mode it is retained until the next switching time is reached.

- Medium-long press(>1 s) of the \wedge button

Pressing the \wedge button for a medium length of time changes the ventilation level to the highest level that can be set

Switching the ventilation off or on

- Medium button press(>1 s) of the v button
Pressing the v button for a medium length of time switches the ventilation off.
- Medium-long press(>1 s) of the ^ button
Pressing the ^ button for a medium length of time switches the ventilation on.

Window detector active

If a window is recognised as open, the window symbol is displayed and operation is blocked.

- Button press of any combination or duration
When the window is open, the window symbol flashes twice to show that the device is locked.
When the window is closed, the window symbol disappears and the operating lock is cancelled.

Activating the operating lock

- Simultaneous medium-long(>1 s) press of the v and + buttons
Pressing both buttons for a medium length of time activates the operating lock and the lock symbol appears on the display. The lock symbol flashes twice to show that the device has been locked.
If both buttons are pressed again for a medium length of time, the lock symbol disappears and the operating lock is cancelled.

Switch off display

- Long press(>4 s) of the O button
If you press and hold the O button, the device displays OFF for 3 seconds and then switches off the display.
If the O button is pressed and held again, the device switches back to the initial state (as specified by the actuator).

Activating the boost function

With the boost function, the output is switched on for a maximum of 5 minutes without temperature control action in order to obtain a temporary increase in temperature.

-  The boost function can be activated only in heating mode and if no temperature drop has been detected.
- Simultaneous medium-long(>1 s) press of the O and + buttons

The boost function is active. The display counts down from 300 seconds and then switches back to normal mode.

To end the boost function prematurely, press the - and O buttons simultaneously for a medium length of time(>1 s).

6 Application programs

ETS search paths: - Indication / Room climate sensor HVAC Standard

Configuration: S-mode standard

Application program available for Room climate sensor HVAC Standard

Name Room climate sensor HVAC Standard 502321

Version 2.1 for ETS versions 5.7.7 and 6.3.0 and higher

from mask version 07B0

Summarized description Multifunctional ETS application programme for the Room climate sensor HVAC Standard.

The application program enables the parameterisable control of fan coil and split unit systems via KNX. It includes configuration options for temperature, operating modes, fan levels, boost and automatic functions.

KNX Data Secure and the update capability via the ETS Service app ensure secure and future-proof commissioning.

7 Scope of functions

- Energy-efficient and user-friendly control of ventilation and split-unit systems
- Precise monitoring and control of temperature
- Intuitive operation via structured display and control surfaces

Segment-based display with:

- Operating mode indication
- Main and secondary display
- Humidity and air quality display
- Display of window status, operating lock, boost function, heating/cooling mode, ventilation, automatic, ventilation, dehumidification

FanCoil control with integrated controller:

- Display/adjustment of set/actual temperature, humidity, operating mode, heating/cooling status
- Fan speed adjustable (on, off, auto, stepped operation)
- Fan level and operating mode feedback
- Objects for manual control

Split unit control:

- Setting the setpoint temperature
- Operating modes: Automatic, Heating, Cooling, Ventilation, Dehumidification, Eco, Boost
- Set fan speed, switch-off possible

Sensors:

- Integrated temperature sensor

KNX functions:

- KNX Data Secure capable
- Updateable by ETS service app
- Device certificate required for safe commissioning

8 General settings

The "Information" parameter page provides information about topics "ETS compatibility" and "KNX Secure". No parameterisation is performed on this parameter page.

General settings of the device are configured and general functions enabled on the "General" parameter page.

8.1 Basic settings

General

The device can correspond to the device type "Fan coil with controller" or "Air conditioning/split unit". The ETS adjusts the selection of available parameters according to the parameterised device type.

The application area enables the use of recommended parameterisations for the current scenario, which can be individually adapted. Please note that all changes made in relation to this parameter setting will be lost when the application area is changed.

The following parameter settings are directly dependent on the parameterised application area:

- Show operating mode on the display
- Operating mode switchable at the touch of a button
- Main display
- Secondary display
- Indication of actual temperature

The "Application area" parameter is preset to "Private area (e.g. at home, holiday flat)". The following parameters are preset as follows for the private area:

- Show operating mode on the display = active
- Operating mode can be switched by touching a button = active
- Main display = target temperature
- Secondary display = actual temperature
- Actual temperature indicator = internal sensor

The "Application area" parameter can be changed to "Public area (e.g. office, hotel)". The following parameters are preset as follows for the public area:

- Show operating mode on the display = inactive
- Operating mode can be switched by touching a button = inactive
- Main display = target temperature
- Secondary display = no temperature

Enabled functions

The following functions can be enabled on the "General" parameter page:

- Temperature measurement

- Operating lock
- On/off function
- Heartbeat function

 These functions are configured on separate parameter pages.

Table of parameters

The following parameters are available on the "General" parameter page under the "General" heading.

Device type	FanCoil with controller Air conditioning/split unit
<p>This parameter defines the device type after commissioning.</p> <p>With "FanCoil with controller", the device can perform heating control and ventilation control.</p> <p>With "Air conditioning/split unit", the device can control air conditioning systems/split units.</p>	

Area of application	Private area (e.g. at home, holiday flat) Public area (e.g. office, hotel)
<p>The application area enables the use of recommended parameterisations for the current scenario, which can be individually adapted. Please note that all changes made in relation to this parameter setting will be lost when the application area is changed.</p> <p>The following parameter settings are directly dependent on the parameterised application area:</p> <ul style="list-style-type: none"> - Show operating mode on the display - Operating mode switchable at the touch of a button - Main display - Secondary display - Indication of actual temperature 	

The following parameters are available under the heading "Enabled -> Sensor system" heading on the "General" parameter page.

Temperature measurement	Active Inactive
<p>The temperature measurement of the device can be centrally enabled at this point. If "Active", the ETS shows further communication object and parameters.</p>	

The following parameters are available under the "Enabled functions -> Control functions" heading on the "General" parameter page.

Operating lock	Active Inactive
<p>The operating lock of the device can be enabled centrally at this point. When "Active", the ETS displays further communication objects and other parameters on the "Display -> Display settings" parameter page.</p>	

On/off function	Active
	Inactive

The on/off function of the device can be enabled centrally at this point.
 When "Active", the ETS displays further communication objects and other parameters for the "Fan coil with controller" device type on the "Heating control -> General" parameter page or for the "Air conditioning/split unit" device type on the "Air conditioning/split unit" parameter page.

The following parameters are available under the "Enabled functions -> Additional functions" heading on the "General" parameter page.

Heartbeat function	Active
	Inactive

The heartbeat function of the device is enabled centrally at this point.

Cycle time for transmission of device status	0 ... 23 h 0... 2 ... 59 min
--	--------------------------------

This parameter defines the interval at which the condition of the device is transmitted to the bus.
 The cycle time can be configured between 1 minute and 23 hours and 59 minutes.

9 Sensor

The following subchapters provide a description of the device functions. Each subchapter consists of the following sections:

- Functional description
- Table of parameters
- Object list

Functional description

The functional description explains the function and provides helpful tips on project design and usage of the function. Cross references support you in your search for further information.

Table of parameters

The table of parameters lists all parameters associated with the function. Each parameter is documented in a table as follows.

Name of the parameter	Parameter values
Parameter description	

Object list

The object list specifies and describes all communication objects associated with the function. Each communication object is documented in a table.

Function	This column contains the function of the communication object.
Name	This column contains the name of the communication object.
Type	This column contains the length of the communication object.
DPT	This column assigns a datapoint type to a communication object. Datapoint types are standardized in order to ensure interoperability of KNX devices.
Flag	This column assigns the communication flags in accordance with the KNX specification.
C-Flag	activates / deactivates the communication of the communication object
R-Flag	enables externally triggered reading of the value from the communication object
W-Flag	enables externally triggered writing of the value to the communication object
T-Flag	enables transfer of a value
U-Flag	enables updating of an object value in case of feedback
I-Flag	enforces updating of the communication object value when the device is switched on (reading at init)

9.1 Room temperature

Basic principles

The device has an integrated temperature sensor, which can be used to measure the room temperature.

A second external sensor connected via bus telegrams can be used to determine the actual value. This external sensor can also be combined with the temperature measurement by the internal sensor, for example in large rooms or halls.

Temperature measurement is activated on the "General" parameter page and configured on the "Sensors -> Room temperature" parameter page. The device offers a temperature measurement depending on the configuration of the "Temperature measurement by" parameter.

The following points should be considered when choosing the installation location for the device or the external sensors:

- The device or temperature sensor should not be integrated in multiple combinations, especially together with flush-mounted dimmers.
- Do not install the temperature sensor in the area of large electrical consumers (avoid heat influences).
- Installation in the vicinity of radiators or cooling systems is not advisable.
- The temperature sensor should not be exposed to direct sun.
- The installation of sensors on the inside of an outside wall might have a negative impact on the temperature measurement.
- Temperature sensors should be installed at least 30 cm away from doors, windows or ventilation devices and at least 1.5 m above the floor.

Temperature measurement and measured value determination

The device has an integrated temperature sensor. This temperature sensor can be used to measure the ambient temperature and forward it to a room temperature controller by means of the 2-byte object "Room temperature - Actual temperature - Status".

The room temperature measurement can optionally be supplemented with an external sensor. The external sensor is linked to the device (for example an additional push-button sensor or a KNX room temperature controller) via the bus by means of the additional 2-byte communication object "Room temperature - External value".

The "Temperature measurement by" parameter on the parameter page "Sensors -> Room temperature" specifies the sensors used to measure the room temperature. The following settings are possible:

- "Internal sensor"
The temperature sensor integrated in the device is activated. Thus, the actual temperature value is determined only locally on the device.
- "Internal sensor and ext. value via bus"

In this setting the internal and external temperature sensor are active. The external sensor must either be a KNX room temperature controller coupled by means of the 2-byte object "Room temperature - External value" or another bus device with temperature detection.

When evaluating the internal and the external sensors, the real actual temperature is made up from the two measured temperature values. The weighting of the temperature values is defined by the parameter "Weighting of measured values". It is thus possible to calibrate the actual temperature measurement, depending on the different installation locations of the sensors or possibly uneven heat distribution inside the room. Often, those temperature sensors that are subject to negative external influences (for example, unfavourable location because of exposure to sun or heater or door / window directly next to it) are weighted less heavily.

Example:

The device has been installed next to the entrance door of the room (internal sensor). An additional external temperature sensor has been mounted on an inner wall in the middle of the room below the ceiling.

Internal sensor: 21.5 °C

External sensor: 22.3 °C

Determination of measured value: 30% to 70%

-> TResult internal = T internal · 0.3 = 6.45 °C,

-> TResult external = Texternal = 22.3 °C · 0.7 = 15.61 °C

-> TResult actual = TResult internal + TResult external = 22.06 °C

Transmission of the temperature

The determined temperature can be transmitted to the bus by means of the 2-byte object "Room temperature - Actual temperature - Status".

The parameter Send actual temperature "On change by" defines the temperature value by which the actual value of the temperature measurement must change so that the actual value is automatically sent via the "Room temperature - Actual temperature - Status" object. Possible temperature value changes lie within a range of 0.1 K and 25.5 K.

In addition, the temperature determined by the room temperature measurement can be transmitted cyclically. The "Cycle time" parameter defines the time rhythm (10 seconds to 24 hours).

- i** It is possible to read out the current actual values at any time via the bus by setting the "read" flag on the object "Room temperature - Actual temperature - Status".
- i** It has to be pointed out that with deactivated cyclical transmission and deactivated automatic transmission, no more temperature telegrams will be transmitted in case of changes.

Calibrating the measured values

In some cases during room temperature measurement, it may be necessary to adjust the single temperature values. Adjustment becomes necessary, for example, if the temperature measured by the sensors stays permanently below or above the actual temperature in the vicinity of the sensor. To determine the temperature deviation, the actual room temperature should be detected with a reference measurement using a calibrated temperature measuring device.

The "Temperature calibration" parameters can be used to configure the positive (temperature increase between 0.1 and 12.7 K) or negative (temperature decrease between -12.8 and -0.1 K) temperature calibration in 0.1 K increments. Thus, the calibration is only set statically once.

- i** The measured value has to be increased, if the value measured by the sensor lies below the actual room temperature. The measured value has to be decreased, if the value measured by the sensor lies above the actual room temperature.
- i** The calibrated temperature value is transmitted to the bus by means of the object "Room temperature - Actual temperature - Status".
When determining the measured value with combined sensors, the two adjusted values are used to calculate the actual value.

9.1.1 Table of parameters

"General" parameter page

Temperature measurement	Active Inactive
This parameter activates the temperature measurement. Additional parameters and objects become visible.	

Parameter page "Sensors -> Room temperature"

Temperature measurement by	internal sensor internal sensor and external value via bus
The "Temperature measurement by" parameter specifies the sensors used to measure the room temperature.	
"Internal sensor": The integrated temperature sensor is activated. Thus, the actual temperature value is determined only locally on the device. In this configuration, the feedback control will start directly after a device reset.	
"Internal sensor and ext. value via bus": The selected temperature sources are combined. The integrated temperature sensor is activated. The "Room temperature - External value" communication object is enabled. The actual temperature value is therefore determined locally on the device and with temperature values received via the bus.	

Weighting of the measured values	10% to 90%
	20% to 80%
	30% to 70%
	40% to 60%
	50% to 50%
	60% to 40%
	70% to 30%
	80% to 20%
	90% to 10%
The weighting of the temperature values measured by the internal sensor and the external value is specified via the bus here. That results in an overall value, which will be used for the further interpretation of the room temperature.	

Sensor calibration	Factory setting Object with separately measured temperature value
<p>Factory setting: The internal sensor works with the factory settings supplied and can be adjusted via a parameter.</p> <p>Object with separately measured temperature value: The internal sensor works after a sensor calibration via the communication object "Room temperature - Sensor calibration - Internal sensor" according to the sensor calibration. Temperature equalisation is then no longer necessary.</p>	
Temperature calibration Internal sensor (0 = inactive)	-12.8...0...12.7
Determines the value in Kelvin by which the internal sensor's measured value is adjusted.	
Temperature calibration External value via bus (0 = inactive)	-12.8...0...12.7
Determines the value in Kelvin by which the external value is calibrated via the bus.	
Transmit actual temperature	on change cyclical On change and cyclical
This parameter defines when the actual temperature is sent to the bus via the "Room temperature - Actual temperature - Status" communication object. Depending on the parameterisation carried out here, further parameters become visible.	
On change	0.1... 3 ...25.5
Determines the extent the value of the room temperature is changed in Kelvin after which the current value is automatically transmitted to the bus by means of the object "Room temperature - Actual temperature - Status".	
Cycle time	0... 15 ...255
<p>This parameter defines the interval at which the determined actual temperature is transmitted to the bus.</p> <p>The cycle time can be parameterised between 10 seconds and 24 hours.</p>	

Actual temperature without calibration	activated deactivated
<p>This parameter determines whether the actual temperature is also sent to the bus without calibration. The actual temperature without calibration is sent to the bus via the "Room temperature - Actual temperature without calibration - Status" communication object.</p> <p>i If no temperature calibration has been parameterised, the communication objects "Room temperature - Actual temperature - Status" and "Room temperature - Actual temperature without calibration - Status" send the same values to the bus.</p>	
Behaviour if sensor has not been calibrated	Do not send temperature value send invalid temperature value (0x7FFF)
<p>After successful ETS commissioning, the device either sends no temperature values or an invalid temperature value (0x7FFF) to the bus if sensor calibration is parameterised via an object with a separately measured temperature value. The behaviour of the device is defined by this parameter.</p>	

9.1.2 Object list

Function	Name	Type	DPT	Flag
Room temperature - Actual temperature - Status	Room temperature - output	2-byte	9,001	C, R, -, T, A
<p>2-byte object for the output of the actual temperature determined by the device (room temperature). Possible value range: -99.9 °C to +99.9 °C / Measuring range of internal temperature sensor: -40 °C to +125 °C.</p> <p>The temperature value is always output in the format "°C".</p>				

Function	Name	Type	DPT	Flag
Room temperature - Actual temperature without calibration - Status	Room temperature - output	2-byte	9,001	C, R, -, T, A
<p>2-byte object for the output of the actual temperature determined by the device without calibration (room temperature). Possible value range: -99.9 °C to +99.9 °C / Measuring range of internal temperature sensor: -40 °C to +125 °C.</p> <p>The temperature value is always output in the format "°C".</p>				

Function	Name	Type	DPT	Flag
Room temperature - Sensor calibration - Internal sensor	Room temperature - Input	2-byte	9,001	C, -, W, -, U
<p>2-byte object for sensor calibration of the internal sensor. Possible range of values: -99.9 °C to +99.9 °C.</p> <p>The temperature value must always be specified in the format "°C".</p>				

Function	Name	Type	DPT	Flag
Room temperature - External value	Room temperature - Input	2-byte	9,001	C, -, W, -, U
<p>2-byte object for coupling an external KNX room temperature sensor or a controller extension. Thus cascading of multiple temperature sensors for room temperature measurement. Possible range of values: -99.9 °C to +99.9 °C.</p> <p>The temperature value must always be specified in the format "°C".</p>				

10 Operating functions

10.1 Operating lock

The device has a separately configurable operating lock. The operating lock can be activated on the "General" parameter page under "Operating functions".

When the operating lock is activated, the ETS enables further parameters for configuring the operating lock under "Automatic operating lock" on the "Display -> Display settings" parameter page.

An operating lock on the operating element can be activated and used as a child safety lock or to prevent operating errors. The operating lock for the device can be switched on and off during operation.

The active operating lock is signalled by the lock symbol icons of the operating element. If the operating element of the appliance is touched when the operating lock is switched on, the lock symbol flashes. This shows that the device is locked. At the same time, the display brightness changes to the value "During operation" for 20 seconds.

- i** If the operating lock is switched on and humidity is measured at the same time, only the lock symbol is shown on the display. The drop symbol is not displayed.

Switching on the operating lock

Operation of the operating element can be disabled by pressing and holding the "v" and "+" control buttons simultaneously (> 1 second).

- i** When the operating lock is switched on, all other operations on the operating element are ignored.

Automatic operating lock

The operating lock can switch on automatically after a certain period of inactivity. This time can be set from 10 seconds to 59 minutes and 59 seconds.

Operating lock via object

The operating lock can be switched on and off via the communication object.

Switching off the operating lock

The operating element can be unlocked by pressing and holding the "v" and "+" control buttons simultaneously (> 1 second).

Behaviour after an ETS programming operation or after the bus voltage returns

The operating lock can be active or inactive after an ETS programming operation or after bus voltage return. The operating lock can also assume the state before the ETS programming process or before the bus voltage failure.

10.1.1 Table of parameters

"General" parameter page

Operating lock	Active Inactive
<p>The operating lock blocks operation of the appliance via the operating element. An operating lock on the operating element can be activated and used as a child safety lock or to prevent operating errors.</p> <p>This parameter activates the operating lock for the device and can be switched on and off during operation.</p> <p>When the operating lock is activated, the ETS enables further parameters for configuring the operating lock under "Automatic operating lock" on the "Display -> Display settings" parameter page.</p> <p>Additional parameters and objects become visible.</p>	

Parameter page "Display -> Display settings"

Automatic operating lock	Active Inactive
<p>The operating lock can switch on automatically after a certain period of inactivity. This parameter activates the automatic operating lock.</p>	

Automatic operating lock after	0 ... 59 min 0 ... 20 ... 59 s
<p>The automatic operating lock switches on after a certain period of inactivity. This time can be set from 10 seconds to 59 minutes and 59 seconds.</p>	

Operating lock via object	Active Inactive
<p>The operating lock can be switched on and off via the communication object. This parameter enables the "Operating lock - Default" communication object.</p>	

After an ETS programming operation or after the bus voltage returns	Behaviour as before Operating lock active Operating lock inactive
<p>The operating lock can be active or inactive after an ETS programming operation or after bus voltage return. The operating lock can also assume the state before the ETS programming process or before the bus voltage failure.</p>	

10.1.2 Object list

Function	Name	Type	DPT	Flag
Operating lock - Status	Display - Output	1-bit	1,003	C, R, -, T, A
<p>1-bit object for outputting the current status of the operating lock (0 = operating lock switched off / 1 = operating lock switched on).</p>				

Function	Name	Type	DPT	Flag
Operating lock - default	Display - Input	1-bit	1,003	C, -, W, T, U
1-bit object for switching the operating lock on and off via object (0 = switch off operating lock / 1 = switch on operating lock).				

10.2 On/off function

The device has a separately configurable on/off function. The switch-on/switch-off function can be activated on the "General" parameter page under "Operating functions".

When the on/off function is activated, the ETS enables further parameters for configuring the on/off function on the "Fan coil with controller -> Heating control -> General" parameter page or on the "Air conditioning/split unit" parameter page.

- i** The device can also be switched on or off with a long press (> 4 seconds) on the centre buttons when the on/off function is inactive.

The switch-on/switch-off function can optionally be used to send value telegrams to the bus when the device is switched on or off. 1-bit values, 1-byte values or scene numbers can be sent to the bus.

When the device is switched off, the current actual temperature can optionally be shown in the main segment of the display.

The secondary display shows "OFF" when the device is switched off.

Depending on the application, the value telegrams can be sent to the bus only when switching off, only when switching on or when switching on and off.

- i** If the product is in the "Off" state and a lock is activated by object, this is tracked in the background.
- i** If the device is switched to the "Off" state, the "Automatic operating lock according to time setting" is updated in the background with the corresponding time.
- i** If the product is set to "Off" mode, the display brightness changes to the brightness value in idle mode after 20 seconds.

10.2.1 Table of parameters

"General" parameter page

On/off function	Active Inactive
<p>The switch-on/switch-off function can optionally be used to send value telegrams to the bus when the device is switched on or off. 1-bit values, 1-byte values or scene numbers can be sent to the bus</p> <p>This parameter is used to activate the on/off function for the device.</p> <p>When the on/off function is activated, the ETS enables further parameters for configuring the on/off function on the "Fan coil with controller -> Heating control -> General" parameter page or on the "Air conditioning/split unit" parameter page.</p> <p>i The device can also be switched on or off with a long press (> 4 seconds) on the centre buttons when the on/off function is inactive.</p> <p>Additional parameters and objects become visible.</p>	

Parameter page "Fan coil with controller -> Heating control -> General"

Indicator of actual temperature in the main segment after switching off	Active Inactive
<p>When the device is switched off, the current actual temperature can optionally be shown in the main segment of the display. This parameter activates or deactivates this indicator when switched off.</p>	
When switching off the display	Switchover to frost/heat protection maintain current operating mode
<p>This parameter defines the switchover behaviour of the operating mode when the display is switched off. It can be switched to frost/heat protection when switched off or the current operating mode can be retained.</p> <p>i This parameter is only available for the "Fan coil with controller" device type.</p>	

Function	No reaction send 1-bit object send 1-byte object Activate scene
This parameter defines the function of the switch-on/switch-off function when the switch-on/switch-off function is activated. no reaction: The device does not send any value telegrams to the bus when it is switched on or off. send 1-bit object: The device sends 1-bit value telegrams to the bus when it is switched on or off. send 1-byte object: The device sends 1-byte value telegrams to the bus when it is switched on or off. Activate scene: the device sends scene number telegrams to the bus when it is switched on or off.	
Send to	Switch off Switch on Switching the device on or off
This parameter defines for the on/off function whether value telegrams are only sent to the bus when switching off, only when switching on or when switching on and off.	
When switching off	Off On
This parameter defines the 1-bit value that is sent to the bus when switching off (0 = Off / 1 = On).	
When switching on	Off On
This parameter defines the 1-bit value that is sent to the bus when switching on (0 = Off / 1 = On).	
When switching off	0...255
This parameter defines the 1-byte value that is sent to the bus when switching off.	
When switching on	0...255
This parameter defines the 1-byte value that is sent to the bus when switching on.	
When switching off	1...64
This parameter defines the scene number that is sent to the bus when switching off.	
When switching on	1...2...64
This parameter defines the scene number that is sent to the bus when switching on.	

10.2.2 Object list

Function	Name	Type	DPT	Flag
On/off function	Display - Output	1-bit	1,001	C, R, -, T, A
1-bit object for outputting the 1-bit value telegram of the switch-on/switch-off function (0 = Off / 1 = On) to the bus.				

Function	Name	Type	DPT	Flag
On/off function Status	Display - Input	1-bit	1,001	C, -, W, T, U
1-bit object for receiving the 1-bit value status of the switch-on/switch-off function (0 = Off / 1 = On) via the bus.				

Function	Name	Type	DPT	Flag
On/off function	Display - Output	1-byte	5,001	C, R, -, T, A
1-byte object for outputting the 1-byte value telegram of the switch-on/switch-off function (0...255) to the bus.				

Function	Name	Type	DPT	Flag
On/off function	Display - Output	1-byte	17,001	C, R, -, T, A
1-byte object for outputting the scene number telegram of the switch-on/switch-off function (1...64) to the bus.				

11 FanCoil with controller

11.1 Heating control

A controller is integrated in the device software, which can be used for single room temperature control. This allows the room temperature to be set to specified set-points through a control process. The controller can transmit command value telegrams to the KNX and thus activate other KNX devices (e.g. heating actuators or fan coil actuators).

All the controller functions (e.g. setpoint temperature specification, operating mode switchover, switchover of the operating mode) are controlled via KNX communication objects (object controller without its own operating elements), meaning that controller operation is possible via controller extensions or visualisations. The source for the room temperature processed by the room temperature controller can be the device's internal temperature measurement or a temperature value received via the bus.

11.1.1 General heating control

11.1.1.1 Name

You can optionally assign a name to the room temperature controller. The names should clarify the use of the output (e.g. "heating living room" or "cooling ceiling office 1"). The names are only used in the ETS in the text of the parameter pages and communication objects.

11.1.1.2 Operating mode

Introduction

A room temperature controller distinguishes between two different operating modes. The operating modes specify whether you want the controller to use its command value to trigger heating systems ("heating" single operating mode) or cooling systems ("cooling" single operating mode). You can also activate mixed operation, with the controller being capable of changing over between "Heating" and "Cooling" either automatically or, alternatively, controlled by a communication object.

In addition, you can establish two-level control operation to control an additional heating or cooling unit. For two-level feedback control, separate command values will be calculated as a function of the temperature deviation between the setpoint and the actual value for the basic and additional levels. The "Operating mode" parameter on the "Fan coil with controller" parameter page defines the operating mode and enables the additional stage(s) if necessary.

-  The parameterised operating mode influences the heating control and the ventilation control.

"Heating" or "cooling" single operating modes

In the single "Heating" or "Cooling" operating modes without any additional level, the controller will always work with one command value. Alternatively, when the additional level is enabled, it will use two command values in the configured operation. Depending on the room temperature determined and on the specified setpoint temperatures of the operating modes, the room temperature controller will automatically decide whether heating or cooling energy is required and calculates the command value for the heating or cooling system.

"Heating and cooling" mixed operating mode

In the "Heating and cooling" mixed operating mode, the controller is capable of triggering heating and cooling systems. In this connection, you can set the change-over behaviour of the operating modes...

- The "Heating/cooling switchover" parameter in the "Fan coil with controller -> Heating control -> General" parameter branch is set to "Automatic by RTR".

In this case, a heating or cooling mode is automatically activated, depending on the determined room temperature and on the specified setpoint temperature. If the room temperature is within the preset deadband neither heating nor cooling will take place (both command values = "0"). The communication object "Setpoint temperature" displays the most recently active setpoint for heating or cooling. If the room temperature is higher than the cooling setpoint temperature, cooling will take place. If the room temperature is higher than the heating setpoint temperature, heating will take place.

When the operating mode is switched over automatically, the information can be actively sent on the bus via the object "Heating/cooling operating mode - Status" to indicate whether the controller is working in heating mode ("1" telegram) or in cooling mode ("0" telegram). In this case, a telegram will be transmitted immediately on changing from heating to cooling (object value = "0") or from cooling to heating (object value = "1"), respectively.

The "Cyclical transmission" parameter enables cyclical transmission (factor setting > "0 min") and specifies the cycle time.

- i** With an automatic operating mode change-over, it should be noted that under certain circumstances there will be continuous change-over between heating and cooling if the deadband is too small! For this reason, you should, if possible, not set the deadband (temperature difference between the setpoint temperatures for the comfort heating and cooling modes) below the default value (2 K).

- The "Heating/cooling switchover" parameter in the "Fan coil with controller -> Heating control -> General" parameter branch is set to "via object".

In this case, the operating mode is controlled via the "Operating mode" object, irrespective of the deadband. This type of change-over can, for example, become necessary if both heating and cooling should be carried out through a one-pipe system (heating and cooling system). For this, the temperature of the medium in the single-pipe system must be changed via the system control. Af-

terwards the heating/cooling operating mode is set via the object (often the single-pipe system uses cold water for cooling during the summer, hot water for heating during the winter).

The "Operating mode" object has the following polarities: "1": heating; "0": cooling. After a reset, the object value will be "0", and the "Operating mode after reset" set in the ETS will be activated. The parameter "Operating mode after reset" can be used to determine which operating mode is activated after a reset. For the "Heating" or "Cooling" settings, the controller will activate the configured heating/cooling operating mode immediately after the initialisation phase. In case of parameterisation "Operating mode before reset" the operating mode which was selected before the reset will be activated.

Setpoint temperatures can be specified for each operating mode in the ETS as part of configuration. It is possible to configure the setpoints for the "Comfort", "Standby" and "Night" modes directly (absolute setpoint setting) or relatively (derivation from basic setpoint temperature). With absolute setpoint setting there is no basic setpoint temperature and also no deadband in the mixed "Heating and cooling" operating mode (if necessary also with additional level). Consequently, the room temperature controller cannot control the switchover of the operating mode automatically, which is why, in this configuration, the setting for the parameter "Heating/cooling switchover" is fixed in the ETS to "via object".

11.1.1.3 Type of control

Introduction

To facilitate convenient temperature control in living or business spaces a specific control algorithm which controls the installed heating or cooling systems is required. Taking account of the preset temperature setpoints and the actual room temperature, the controller thus determines command values which trigger the heating or the cooling system. The control system (control circuit) consists of a room temperature controller, a valve drive or an actuator with switching output signals (e. g. heating actuator when ETD electrothermal drives are used), the actual heating or cooling element (e. g. radiator or cooling ceiling) and of the room. This results in a controlled system (see figure 12).

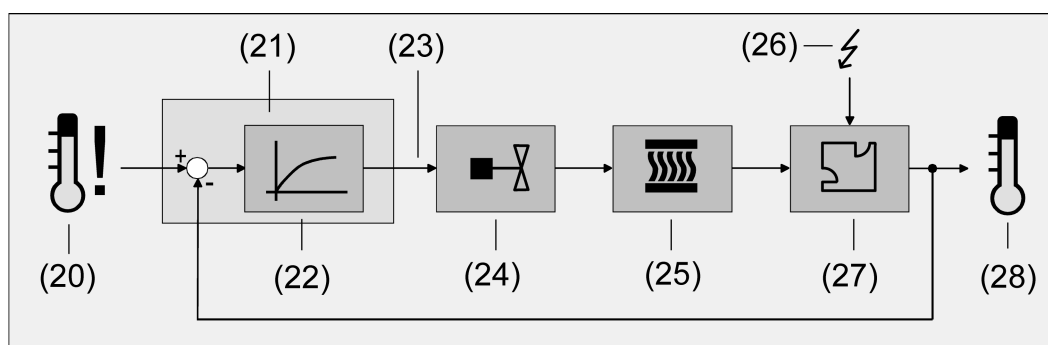

Figure 12: Controlled system of single-room temperature control

- (20) Setpoint temperature specification
- (21) Room temperature controller

- (22) Control algorithm
- (23) Command value
- (24) Valve control (valve drive, ETD, heating actuator, ...)
- (25) Heat/cold exchanger (radiator, cooling ceiling, FanCoil, ...)
- (26) Fault variable (sunlight penetration, outdoor temperature, illumination systems, ...)
- (27) Room
- (28) Actual value of room temperature

The controller evaluates the actual room temperature value (28) and compares it with the specified setpoint temperature (20). With the aid of the selected control algorithm (22), the command value (23) is then calculated from the difference between the actual and the setpoint temperature. The command value controls valves or fans for heating or cooling systems (24), meaning that heating or cooling energy in the heat or cold exchangers (25) is passed into the room (27). Regular readjustment of the command value means that the controller is able to compensate for setpoint / actual temperature differences caused by external influences (26) in the control circuit. In addition, the flow temperature of the heating or cooling circuit influences the control system which necessitates adaptations of the variable.

The room temperature controller facilitates either proportional/integral (PI) feedback control as a continuously working or switching option, or, alternatively, switching 2-point feedback control.

i In some practical cases, it can become necessary to use more than one control algorithm. For example, in bigger systems using floor heating, one control circuit which solely triggers the floor heating can be used to keep the latter at a constant temperature. The radiators on the wall, and possibly even in a side area of the room, will be controlled separately by an additional level with its own control algorithm. In such cases, distinction must be made between the different types of control, as floor heating systems, in most cases, require control parameters which are different to those of radiators on the wall, for example. It is possible to configure up to four independent control algorithms in two-level heating and cooling operation.

The command values calculated by the control algorithm are output via the "Heating command value" or "Cooling command value" communication objects. Depending on the control algorithm selected for the heating and/or cooling mode, the format of the command value objects is, among other things, also specified. In this way, 1-bit or 1-byte command value objects can be created. The control algorithm is specified by the parameters "Type of control" in the parameter branch "FanCoil with controller -> Heating control -> General" and, if necessary, also with a distinction of the basic and additional levels.

11.1.1.3.1 Continuous PI control

PI control is an algorithm which consists of a proportional part and an integral part. Through the combination of these control properties, you can obtain room temperature control as quickly and precisely as possible without or only with low deviations.

When you use this algorithm, the room temperature controller will calculate a new continuous command value in cycles of 30 seconds and transmit it to the bus via a 1-byte value object if the calculated command value has changed by a specified percentage. The parameter "On change by (0 = inactive)" in the parameter branch "Fan-Coil with controller -> Heating control -> General -> Command value output" specifies the change interval in percent.

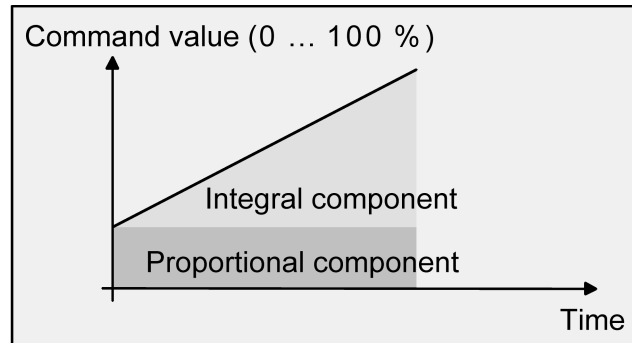

Figure 13: Continuous PI control

- i** An additional heating or cooling stage as PI control works in the same way as the PI control of the basic stage, with the difference that the setpoint will shift, taking into account the configured step width.

11.1.1.3.2 Switching PI control

With this type of feedback control, the room temperature will also be kept constant by the PI control algorithm. Taking the mean value for a given time, the same behaviour of the control system will result as you would obtain with a continuous controller. The difference compared with continuous feedback control is only the way how the command value is output. The command value calculated by the algorithm in cycles of every 30 seconds is internally converted into a pulse-width-modulated (PWM) command value signal and sent to the bus via a 1-bit switching object. The mean value of the command signal resulting from this modulation is a measure for the centred control valve position and thus a reference for the set room temperature in consideration of the cycle time than can be set with the parameter "PWM cycle time" in the parameter branch "FanCoil with controller -> Heating control -> General -> Command value output".

A shift of the mean value, and thus a change in the heating capacity, can be obtained by changing the duty factor of the switch-on and switch-off pulses of the command value signal.

For a command value of 0% (permanently off) or of 100% (permanently on), a command value telegram corresponding to the command value ("0" or "1") will always be sent after a cycle time has elapsed.

For switching PI control, the controller will always use continuous command values for internal calculation. Such continuous values can additionally be sent to the bus via a separate 1-byte value object, for example, as status information for visualisation purposes (if necessary, also separately for the additional levels). The status value objects will be updated at the same time as the command value is output. The para-

meters "On change by (0 = inactive)" and "Cyclical (0 = inactive)" have no function here. An additional heating or cooling stage as switching PI control works in the same way as the PI control of the basic stage, with the exception that the setpoint will shift, taking account of the parameterised step width. All PWM control options will use the same cycle time.

Cycle time

The pulse-width-modulated command values are mainly used for activating electrothermal drives (ETD). In this regard, the room temperature controller transmits the switching command value telegrams to an actuator equipped with semiconductor switching elements to which the drives are connected (e. g. heating actuator). By setting the cycle time of the PWM signal on the controller, you can adapt the feedback control to the drives used. The cycle time sets the switching frequency of the PWM signal and allows adaptation to the adjusting cycle times of the valve drives used (the adjusting time it takes the drive to bring the valve from its completely closed to its completely opened position). In addition to the adjusting cycle time, take account of the dead time (the time in which the valve drives do not show any response when being switched on or off). If different actuators with different adjusting cycle times are used, take account of the longest of the times. Always note the information given by the manufacturers of the actuators.

During cycle time configuration, a distinction can always be made between two cases:

Case 1: Cycle time $> 2 \times$ adjusting cycle time of the electrothermal drives used (ETA)

In this case, the switch-on or switch-off times of the PWM signal are long enough for the actuators to have sufficient time to fully open or fully close within a given time period.

– Advantage:

The desired mean value for the command value and thus for the required room temperature will be set relatively precisely, even for several actuators triggered at the same time.

– Disadvantages:

It should be noted, that, due to the full valve lift to be continuously 'swept', the life expectancy of the actuators can diminish. For very long cycle times (> 15 minutes) with less sluggishness in the system, the heat emission into the room, for example, in the vicinity of the radiators, can possibly be non-uniform and be found disturbing.

i This setting is recommended for sluggish heating systems (such as underfloor heating).

i Even for a bigger number of triggered actuators, maybe of different types, this setting can be recommended to be able to obtain a better mean value of the adjusting travels of the valves.

Case 2: Cycle time $<$ adjusting cycle time of the electrothermal drives used (ETA)

In this case, the switch-on or switch-off times of the PWM signal are too short for the actuators to have enough time to fully open or fully close within a given period.

– Advantages:

This setting ensures continuous water flow through the radiators, thus facilitating uniform heat emission into the room.

If only one valve drive is triggered the controller can continuously adapt the command value to compensate the mean value shift caused by the short cycle time, thus setting the desired room temperature.

– Disadvantages:

If more than one drive is triggered at the same time the desired mean value will become the command value, which will result in a very poor adjustment of the required room temperature, or in adjustment of the latter with major deviations, respectively.

The continuous flow of water through the valve, and thus the continuous heating of the drives causes changes to the dead times of the drives during the opening and closing phase. The short cycle time and the dead times means that the required command value (mean value) is only set with a possibly large deviation. For the room temperature to be regulated constantly after a set time, the controller must continually adjust the command value to compensate for the mean value shift caused by the short cycle time. Usually, the control algorithm implemented in the controller (PI control) ensures that control deviations are compensated.

i This setting is recommended for quick-reaction heating systems (such as surface radiators).

11.1.1.3.3 Adapting the PI control

In a building, different systems can be installed which heat up or cool down a room. One option is to uniformly heat or cool the surroundings via heat transfer media (preferably water or oil) in connection with room air convection. Such systems are used, for example, with wall mounted heaters, underfloor heating or cooling ceilings. Alternatively or additionally forced air systems may heat or cool rooms. In most cases such systems are electrical forced hot air systems, forced cool air systems or refrigerating compressors with fan. Due to the direct heating of the room air such heating and cooling systems work quite swiftly.

The control parameters need to be adjusted so that the PI control algorithm may efficiently control all common heating and cooling systems thus making the room temperature control work as fast as possible and without deviation. Certain factors can be adjusted with a PI control that can influence the control behaviour quite significantly at times. For this reason, the room temperature controller can be set to predefined control parameters for the most common heating and cooling systems. In case the selection of a corresponding heating or cooling system does not yield a satisfactory result with the default values, the adaptation can optionally be optimised using control parameters.

Predefined control parameters for the heating or cooling stage and, if applicable, also for the additional stages are adjusted via the "type of heating" or "type of cooling" parameters. These fixed values correspond to the practical values of a properly planned and executed air conditioning system and will result in an ideal behaviour of the temperature control. The heating and cooling types shown in the following tables can be set for heating and cooling operation.

The following table shows predefined control parameters and recommended control types for heating systems:

Type of heating	Proportional range (preset)	Reset time (preset)	recommended PI control type	recommended PWM cycle time
Heat water heating	1 Kelvin	830 minutes	constant/PWM	15 min.
Underfloor heating	1.5 Kelvin	1000 minutes	PWM	15-20 min.
Electrical heating	1 Kelvin	830 minutes	PWM	10-15 min.
Blower coil unit	1 Kelvin	500 minutes	constant	---
Split unit (split climate control unit)	1 Kelvin	500 minutes	PWM	10-15 min.

The following table shows predefined control parameters and recommended control types for cooling systems:

Cooling type	Proportional range (preset)	Reset time (preset)	recommended PI control type	recommended PWM cycle time
Cooling ceiling	1 Kelvin	830 minutes	PWM	15-20 min.
Blower coil unit	1 Kelvin	500 minutes	constant	---
Split unit (split climate control unit)	1 Kelvin	500 minutes	PWM	10-15 min.
Underfloor cooling	1.5 Kelvin	1000 minutes	PWM	15-20 min.

If the "Type of heating" or "Type of cooling" parameters are set to "Via control parameters", it is possible to adjust the control parameters manually. The feedback control may be considerably influenced by presetting the proportional range for heating or for cooling (P component) and the reset time for heating or for cooling (I component).

- i** Even small adjustments of the control parameters will lead to noticeably changed control behaviour!

- i** The adaptation should start with the control parameter setting for the corresponding heating or cooling system according to the specified fixed values mentioned in the above tables.

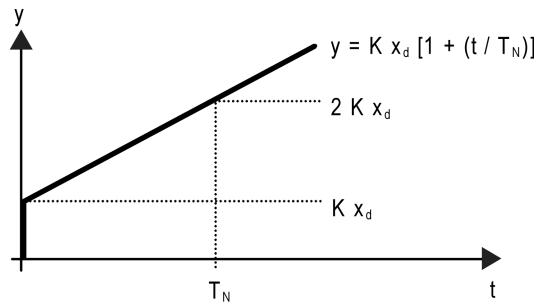

Figure 14: Function of the command value of a PI control

- y: Command value
- x_d : control difference ($x_d = x_{set} - x_{act}$)
- $P = 1/K$: Configurable proportional band
- $K = 1/P$: Gain factor
- T_N : configurable reset time

PI control algorithm: Command value $y = K x_d [1 + (t / T_N)]$

Deactivation of the reset time (setting = "0") ->

P control algorithm: Command value $y = K x_d$

Parameter setting	Effect
P: Small proportional range	large overshoot in case of setpoint changes (possibly permanently), quick adjustment to the setpoint
P: Large proportional range	no (or small) overshooting but slow adjustment
T_N : Short reset time	fast compensation of control deviations (ambient conditions), risk of permanent oscillations
T_N : Long reset time	slow compensation of control deviations

Effects of the settings for the control parameters

11.1.1.3.4 2-point feedback control

2-point feedback control represents a very simple temperature control. For this type of feedback control, two hysteresis temperature values are set. The actuators are triggered by the controller via switch-on and switch-off command value commands (1-bit type). A constant command value is not calculated for this type of control.

The room temperature is also evaluated by this type of control in cycles every 30 seconds. Thus the command values change, if required, only at these times. The disadvantage of a continuously varying temperature as a result of this feedback control option is in contrast with the advantage of this very simple 2-point room temperature control.

- i** Quick-reaction heating or cooling systems should not be triggered by a 2-point feedback control system, for this can lead to very significant exceeding of the temperature, thus resulting in a loss of comfort.
- i** When presetting the hysteresis limiting values, you should distinguish between the operating modes.

"Heating" or "cooling" single operating modes

In heating mode, the controller will turn on the heating when the room temperature has fallen below a preset limit. In heating mode, the feedback control will only turn off the heating once a preset temperature limit has been exceeded. In cooling mode, the controller will turn on the cooling system when the room temperature has exceeded a preset limit. The control system will only turn off the cooling system once the temperature has fallen below a preset limit. In this context, the command value "1" or "0" will be output, depending on the switching status, if the temperature exceeds or falls below the hysteresis limits.

The hysteresis limits of both operating modes can be configured in the ETS.

The following two images each show a 2-point feedback control for the individual operating modes "Heating" (see figure 15) or "Cooling" (see figure 16). The images take two temperature setpoints, one-stage heating or cooling and non-inverted command value output into account.

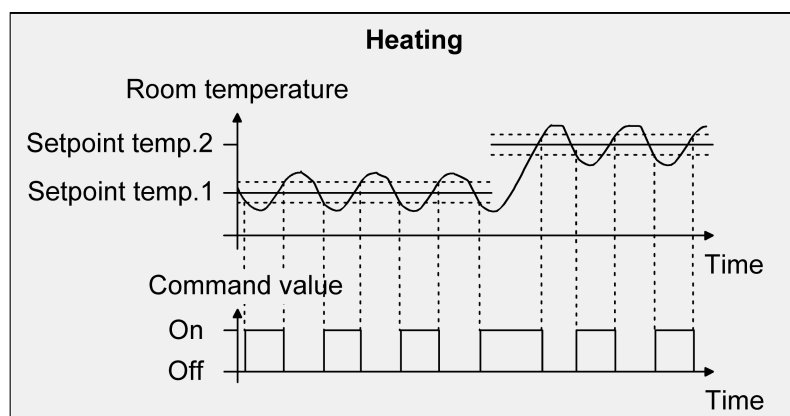

Figure 15: 2-point feedback control for the single "Heating" operating mode

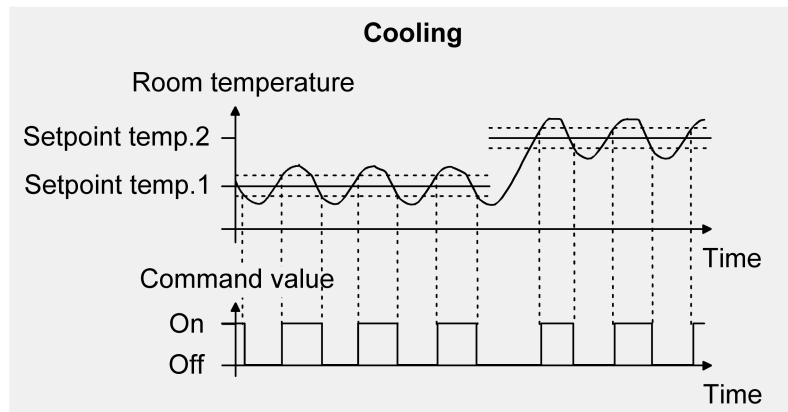

Figure 16: 2-point feedback control for the single "Cooling" operating mode

- i** An additional 2-point feedback control heating or cooling level works the same as the 2-point feedback control of the basic level. The difference is that the setpoint and the hysteresis values will shift taking into account the configured level offset.

"Heating and cooling" mixed operating mode

In mixed operation, a distinction is made whether the change-over between heating and cooling is to be effected automatically or in a controlled way through the object:

- With automatic operating mode change-over, in the heating mode the controller will turn on the heating when the room temperature has fallen below a preset hysteresis limit.

In this case, as soon as the room temperature exceeds the setpoint of the current operating mode, the feedback control will turn off the heating in the heating mode.

In the same way, in cooling mode, the controller will turn on the cooling system when the room temperature has exceeded a preset hysteresis limit.

As soon as the room temperature falls below the setpoint of the current operating mode, the feedback control will turn off the cooling system in the cooling mode.

Thus, in mixed operation, there is no upper hysteresis limit for heating or no lower one for cooling, respectively, for these values would be in the deadband. Within the deadband, neither heating nor cooling will take place.

- With an operating mode switchover via the object, in heating mode, the controller will turn on the heating when the room temperature has fallen below a preset hysteresis limit.

The feedback control will only turn off the heating in the heating mode once the preset upper hysteresis limit has been exceeded.

In the same way, in cooling mode, the controller will turn on the cooling system when the room temperature has exceeded a preset hysteresis limit.

The feedback control will only turn off the cooling system in the cooling mode once the temperature has fallen below the preset lower hysteresis limit.

As with the individual operating modes of heating or cooling, there are two hysteresis limits per operating mode.

Although there is a deadband for the calculation of the temperature setpoints for cooling, it has no influence on the calculation of the two-point command value, as the operating mode is switched over "manually" through the corresponding object.

Within the hysteresis spans, it thus will be possible to request heating or cooling energy for temperature values that are located within the deadband.

The following two images show 2-point feedback control for the mixed operating mode "Heating and cooling", distinguishing between heating mode (see figure 17) and cooling mode (see figure 18). The images take two temperature setpoints, a non-inverted command value output and an automatic operating mode switchover into account. When the operating mode is switched over via the object, an upper hysteresis for heating and a lower hysteresis for cooling are active.

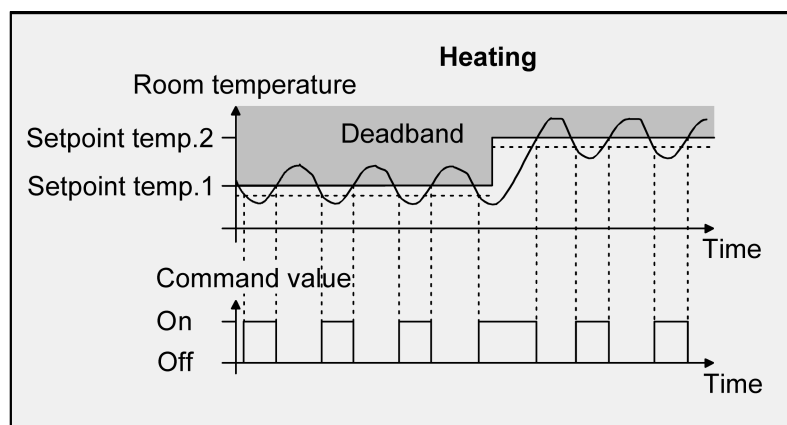

Figure 17: 2-point feedback control for mixed "Heating and cooling" mode with active heating mode

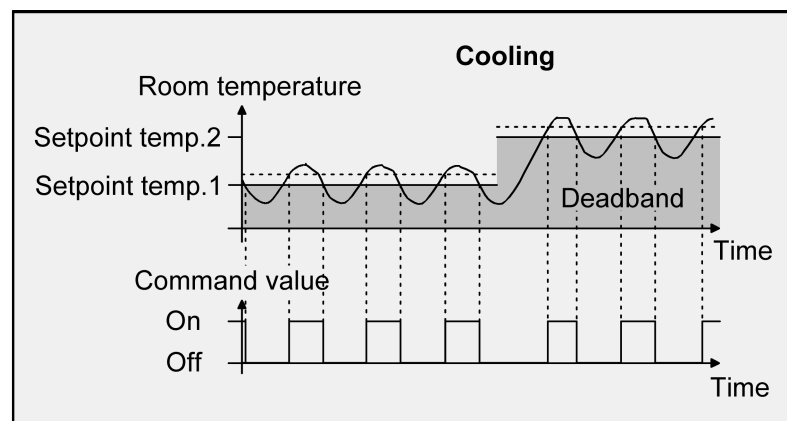

Figure 18: 2-point feedback control for mixed "Heating and cooling" mode with active cooling operation

The command value "1" or "0" will be output, depending on the switching status, if the temperature exceeds or falls below the hysteresis limits or the setpoints.

- i** An additional 2-point feedback control heating or cooling level works the same as the 2-point feedback control of the basic level. The difference is that the setpoint and the hysteresis values will shift taking into account the configured level offset.

11.1.1.3.5 Adapting the 2-point feedback control

2-point feedback control represents a very simple temperature control. For this type of feedback control, two hysteresis temperature values are set. The upper and lower temperature hysteresis limits can be adjusted via parameters.

It has to be considered that:

- a small hysteresis will lead to smaller temperature variations but to a higher KNX bus load,
- a large hysteresis switches less frequently but will cause uncomfortable temperature variations.

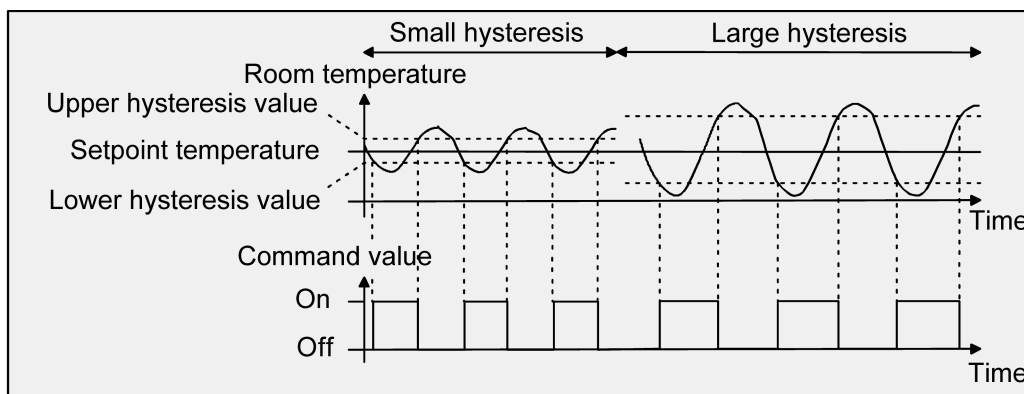

Figure 19: Effects of the hysteresis on the switching behaviour of a 2-point feedback control command value

11.1.1.4 Disabling functions

Disable controller

Certain operation conditions may require the deactivation of the room temperature control. For example, the controller can be switched-off during the dew point mode of a cooling system or during maintenance work on the heating or cooling system. When set to "Active", the "Controller output disabling object" parameter in the "Fan-Coil with controller -> Heating control -> General" parameter node enables the 1-bit object - "Command value outputs - Disable". In addition, the controller disable function can be switched off when set to "Inactive".

In case a "1" telegram is received via the enabled disable object, the room temperature control will be completely deactivated. In this case, all the command values are equal to "0"/"OFF" (wait 30 s for update interval of the command values).

- i** The controller, however, can be operated in this case via the communication objects.

Disable additional level

The additional stage can be separately disabled when in two-stage heating or cooling mode. When set to "Active", the parameter "Additional level disabling object" in the parameter node "Room temperature controller -> RTC - General" enables the

1-bit object "Command value outputs - Additional level - Disable". In addition, the disable function of the additional level can be switched off when set to "Inactive". In case a "1" telegram is received via the enabled disable object, the room temperature control is completely deactivated by the additional level. The command value of the additional level is "0" while the basic level continues to operate.

Disabling operation is always inactive after a device reset (bus voltage return, ETS programming operation).

11.1.1.4.1 Objects for command value output disabling

Function	Name	Type	DPT	Flag
Command value outputs - Disabling	RTC Input	1-bit	1,001	C, -, W, -, U
<p>1-bit object used to disable the command value outputs.</p> <p>In case a "1" telegram is received via the enabled disable object, the room temperature control will be completely deactivated. In this case, all the command values are equal to "0"/"OFF" (wait 30 s for update interval of the command values).</p>				
Function	Name	Type	DPT	Flag
Command value outputs - Additional value - Disabling	RTC Input	1-bit	1,001	C, -, W, -, U
<p>1-bit object used to disable the command value outputs of the additional level.</p> <p>In case a "1" telegram is received via the enabled disable object, the room temperature control is completely deactivated by the additional level. The command value of the additional level is "0" while the basic level continues to operate.</p>				

11.1.1.5 Reset behaviour

Additional information on the operating mode after a reset

The operating mode to be activated after the bus voltage returns or after an ETS programming procedure can be specified in the ETS by the parameter "Operating mode after reset". The following settings are possible here...

- "Comfort" -> The Comfort mode will be activated after the initialisation phase.
- "Standby" -> The standby mode will be activated after the initialisation phase.
- "Night" -> The Night mode will be activated after the initialisation phase.
- "Frost/heat protection" -> The frost/heat protection mode will be activated after the initialisation phase.
- "Restore operating mode before reset" -> The mode set before a reset according to the operating mode objects will be restored after the initialisation phase of the device. Operating modes set by a function with a higher priority before the reset (Forced, Window status, Presence status) are not effected.

11.1.1.6 "Room temperature controller - General" parameters

Name of controller	40-character free text
The text entered in this parameter is used to label the controller in the ETS parameter window (e. g. "Kitchen control", "Bathroom temperature"). The text is not programmed in the device.	
Operating mode	Heating Cooling Heating and cooling Basic and additional heating Basic and additional cooling Basic and additional heating and cooling
<p>The room temperature controller distinguishes between two different operating modes. The operating modes specify whether you want the controller to use its command value to trigger heating systems ("heating" single operating mode) or cooling systems ("cooling" single operating mode). You can also activate mixed operation, with the controller being capable of changing over between "Heating" and "Cooling" either automatically or, alternatively, controlled by a communication object.</p> <p>In addition, you can establish two-level control operation to control an additional heating or cooling unit. For two-level feedback control, separate command values will be calculated as a function of the temperature deviation between the setpoint and the actual value and transmitted to the bus for the basic and additional levels. This parameter specifies the operating mode and, if necessary, enables the additional level(s).</p> <p>i The parameter is set on the "Fan coil with controller" parameter page.</p>	
Command values for heating and cooling	To separate objects (4-pipe / 2 circuits) To shared object (2-pipe / 1 circuit)
<p>If the parameter is set "to separate objects (4-pipe / 2 circuits)", the command value for heating and cooling is sent to separate objects.</p> <p>If the parameter is set "to shared object (2-pipe / 1 circuit)", the command value is transmitted to a shared object during heating or cooling.</p> <p>i "To shared object (2-pipe / 1 circuit) is used if the same heating system is used to cool the room in the summer and used to heat the room in the winter.</p> <p>This parameter is visible in mixed operating modes "Heating and cooling" and "Basic and additional heating and cooling".</p> <p>i The parameter is set on the "Fan coil with controller" parameter page.</p>	

Additional separate command value objects	Active Inactive
<p>If the parameter is set to "active", two separate objects "heating command value" and "cooling command value" are displayed in addition to the shared object "heating/cooling command value". These objects are for both visualisation purposes and also rooms with, for example, combined wall heating/cooling and separate underfloor heating.</p> <p>This parameter is visible in mixed operating modes "Heating and cooling" and "Basic and additional heating and cooling" with the output of the command values to a shared object.</p>	
Type of heating control (if applicable, for basic and additional level)	Continuous PI control Switching PI control (PWM) Switching 2-point feedback control
<p>Selecting a feedback control algorithm (PI or 2-point) with data format (1-byte or 1-bit) for the heating system.</p>	
Type of heating (if applicable, for basic and additional level)	Hot water heater (1.0 K / 830 min) Underfloor heating (1.5 K / 1000 min) Electric heating (1.0 K / 830 min) Fan coil unit (1.0 K / 500 min) Split unit (1.0 K / 500 min) Via control parameter
<p>Adapting the PI algorithm to different heating systems using predefined values for the proportional range and reset time control parameters.</p> <p>With the "Using control parameters" setting, it is possible to set the control parameters in a manner deviating from the predefined values within specific limits.</p> <p>This parameter is only visible if "Type of heating control = Continuous PI control".</p>	
Proportional range	1 ...12.7 K
<p>Separate setting of the "Proportional range" control parameter.</p> <p>This parameter is only visible if "Type of heating = via control parameter" and the heating control type "PI control".</p>	
Reset time (0 = inactive)	0... 830 ...2550 min
<p>Separate setting of the "Reset time" control parameter.</p> <p>This parameter is only visible if "Type of heating = via control parameter" and "Control type = PI control".</p>	
Lower hysteresis limit	-12.8...- 0.5 K
<p>Definition of bottom hysteresis (switch-on temperatures) of the heating.</p> <p>This parameter is only visible if "Type of heating control = Switching 2-point feedback control (ON/OFF)".</p>	

Upper hysteresis limit	0.5...12.7 K
Definition of top hysteresis (switch-off temperatures) of the heating. This parameter is only visible if "Type of heating control = Switching 2-point feedback control".	
Type of control (if applicable, for basic and additional level)	Continuous PI control Switching PI control (PWM) Switching 2-point feedback control
Selecting a feedback control algorithm (PI or 2-point) with data format (1-byte or 1-bit) for the cooling system	
Type of cooling (if applicable, for basic and additional level)	Cooling ceiling (1.0 K / 830 min) Fan coil unit (1.0 K / 500 min) Split unit (1.0 K / 500 min) Floor cooling (1.5 K / 1000 min) Via control parameter
Adapting the PI algorithm to different cooling systems using predefined values for the proportional range and reset time control parameters. With the "Using control parameters" setting, it is possible to set the control parameters in a manner deviating from the predefined values within specific limits. This parameter is only visible if "Type of cooling control = PI control".	
Proportional range	1...5...12.7 K
Separate setting of the "Proportional range" control parameter. This parameter is only visible if "Type of cooling = via control parameter" and the cooling control type "PI control".	
Reset time (0 = inactive)	0...830...2550 min
Separate setting of the "Reset time" control parameter. This parameter is only visible if "Type of cooling = via control parameter" and the cooling control type "PI control".	
Lower hysteresis limit	-12.8...-0.5 K
Definition of bottom hysteresis (switch-off temperatures) of the cooling. This parameter is only visible if "Type of cooling control = Switching 2-point control".	
Upper hysteresis limit	0.5...12.7 K
Definition of top hysteresis (switch-on temperatures) of the cooling. This parameter is only visible if "Type of cooling control = Switching 2-point control".	

Heating/cooling switchover	Automatic via RTC Via object
<p>In a configured mixed mode it is possible to switch over between heating and cooling.</p> <p>With "Automatic by RTC": Depending on the operating mode and the room temperature, the switching over takes place automatically.</p> <p>With "via object": The switchover takes place only via the object "Operating mode".</p>	
Disabling object additional level	Active Inactive
<p>The additional stages can be separately disabled via the bus. The parameter enables the disable object as necessary.</p> <p>This parameter is only visible in two-level heating and cooling operation.</p>	
Disabling object controller output	Active Inactive
<p>This parameter enables the "Disable command value outputs" object. If the controller is disabled, there is no feedback control until enabled (command values = 0).</p>	
Show operating mode on the display	Active Inactive
<p>This parameter determines whether the current operating mode is shown on the display during operation</p>	
Operating mode switchable at the touch of a button	Active Inactive
<p>This parameter determines whether the current operating mode can be switched by pressing a button during operation. Another parameter defines the switching behaviour.</p>	
Switch-over behaviour	Comfort / Standby / Night Comfort/Standby Comfort/Night Standby/Night
<p>This parameter defines the switchover behaviour of the operating mode during operation at the push of a button.</p>	
Extended settings	Active Inactive
<p>Extended parameters can be enabled in the operating modes category.</p> <p>As soon as the extended parameters are inactive, they are written to the device with their default values.</p>	

Additionally display eco symbol in standby/night mode	Active Inactive
An additional eco symbol is shown on the display during operation if the controller is operating in standby or night operating mode.	
Heating/cooling process indicated by symbol	Active Inactive
An additional symbol is shown on the display during operation if the controller is actively heating or cooling.	
Operating mode after reset	Heating Cooling Operating mode before reset
This parameter specifies which operating mode is set immediately after a device reset. This parameter is only displayed if an operating mode is selected that includes both heating and cooling.	
Operation mode after reset	Restore operating mode before reset Comfort Standby Night Frost/heat protection
This parameter specifies which operating mode is set immediately after a device reset. With "Restore operation mode before reset": The mode set before a reset according to the operating mode object will be restored after the initialising phase of the device. Operating modes set by a function with a higher priority before the reset (Forced, Window status, Presence status) are not effected.	

11.1.1.7 Objects for operating mode and setpoints

Function	Name	Type	DPT	Flag
Operating mode	RTR ... - Input	1-bit	1,100	C, -, W, -, U
1-bit object used to switch over the operating mode. The "Operating mode" object has the following polarities: "1": heating; "0": cooling. After a reset, the object value will be "0", and the "Operating mode after reset" set in the ETS will be activated. The parameter "Operating mode after reset" can be used to determine which operating mode is activated after a reset.				

Function	Name	Type	DPT	Flag
Operating mode - status	RTR ... - Output	1-bit	1,100	C, R, -, T, A
<p>When the operating mode is switched, the information can be actively sent to the bus by means of the object "Operating mode - Status" to indicate whether the controller is working in heating mode ("1" telegram) or cooling mode ("0" telegram). In this case, a telegram will be transmitted immediately on changing from heating to cooling (object value = "0") or from cooling to heating (object value = "1"), respectively.</p>				

11.1.2 Operating mode and setpoints

Introduction - Operating modes

The room temperature controller has various operating modes. The selection of these modes will, for example, facilitate the activation of different temperature setpoints, depending on the presence of a person, on the state of the heating or cooling system, on the time of the day, or on the day of the week. The following operating modes can be distinguished:

- **Comfort**

Comfort mode is usually activated if persons are in a room, and the room temperature should, for this reason, be adjusted to an adequately convenient value. The switchover to this operating mode can take place either by specifying an operating mode via the operating mode switchover or with presence control, for example, using a PIR presence detector on the wall or a ceiling mounted presence detector.
- **Standby**

If a room is not used during the day because persons are absent, you can activate the Standby mode. Thereby, you can adjust the room temperature on a standby value, thus to save heating or cooling energy, respectively
- **Night**

During the night hours or during the absence of persons for a longer time, it mostly makes sense to adjust the room temperature to lower values for heating systems (e. g. in bedrooms). In this case, cooling system can be set to higher temperature values, if air conditioning is not required (e. g. in offices). For this purpose, you can activate the Night mode.
- **Frost/heat protection**

Frost protection will be required if, for example, the room temperature must not fall below critical values while the window is open. Heat protection can be required where the temperature rises too much in an environment which is always warm, mainly due to external influences. In such cases, you can activate the Frost/heat protection operation and prescribe some temperature setpoint of its own for either option, depending on whether "Heating" or "Cooling" has been selected, to prevent freezing or overheating of the room.
- **Comfort extension (temporary Comfort mode)**

You can activate the comfort extension from the Night or Frost/heat protection mode (not triggered by the "Window status" object) and use it to adjust the room temperature to a comfort value for some time if, for example, there are people in the room during the night hours. This mode can exclusively be activated via the presence object. The comfort extension option will be automatically deactivated after a definable time has elapsed, or by receiving a presence object value = "0". You cannot retrigger this extension.

i You can assign your own setpoint temperature to the "Heating" or "Cooling" operating modes for each operating mode.

Operating mode switchover

The operating mode is switched by the "Operating mode - Preset" object.

During the running time, the operating mode can be changed over through this value object immediately after the receipt of only one telegram. In this connection, the value received will set the operating mode. In addition, a second 1-byte object is available which, by forced control and through a higher level, can set an operating mode, irrespective of any other switchover options.

Taking the priority into account, a specific switchover hierarchy will result from the operating mode switchover by the objects, a distinction being made between presence detection by the presence button (see figure 20) or the presence detector (see figure 21). In addition, the status of the windows in the room can be evaluated using the "Frost/heat protection - Window contact - Status" object, meaning that, when a window is open, the controller can switch to frost/heat protection mode, irrespective of the set operating mode, in order to save energy.

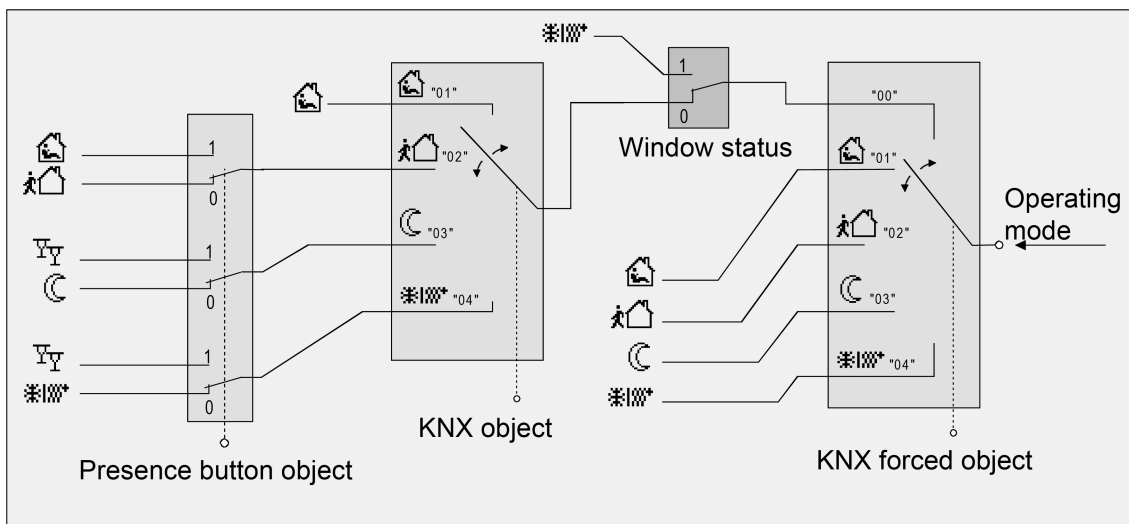

Figure 20: Operating mode switchover through KNX object with presence button

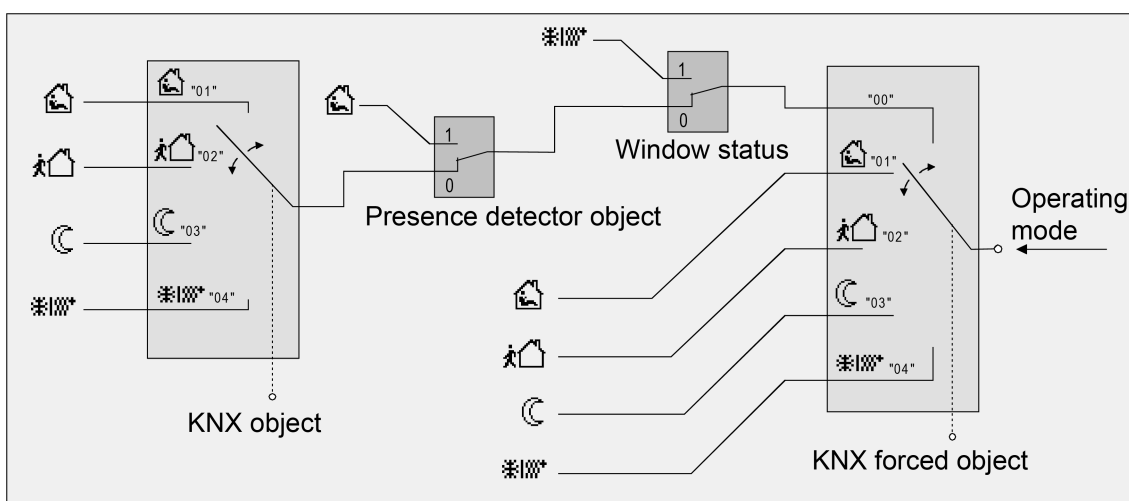

Figure 21: Operating mode switchover through KNX object with presence detector

Object value Operating mode	Object value Forced ob- ject Oper. m.	Object Window status	Pres- ence button	Pres- ence detector	resulting operating mode
00	00	0	X	0	No modification
01	00	0	0	-	Comfort
02	00	0	0	-	Standby
03	00	0	0	-	Night
04	00	0	0	-	Frost/heat protec- tion
01	00	0	1	-	Comfort
02	00	0	1	-	Comfort
03	00	0	1	-	Comfort ex- tension
04	00	0	1	-	Comfort ex- tension
01	00	0	-	0	Comfort
02	00	0	-	0	Standby
03	00	0	-	0	Night
04	00	0	-	0	Frost/heat protec- tion
X	00	0	-	1	Comfort
X	00	1	-	X	Frost/heat protec- tion
X	00	1	X	-	Frost/heat protec- tion
X	01	X	X	X	Comfort
X	02	X	X	X	Standby
X	03	X	X	X	Night
X	04	X	X	X	Frost/heat protec- tion

Status of the communication objects and the resulting operating mode

X: Status irrelevant

-: Not possible

- i** After the mains voltage returns or after an ETS programming operation, the value corresponding to the set operating mode is actively transmitted to the bus if the "Transmit" flag is set.
- i** In parameterisation of a presence button: the presence object will be active ("1") for the period of an active comfort extension. The presence object will be automatically deleted ("0") if the comfort extension is stopped after the extension time has elapsed, or if the operating mode has been changed by an oper-

ation through the switchover objects or a forced operating mode is deactivated by the KNX forced object (forced object -> "00"). The controller therefore automatically resets the status of the presence button when an object value is received via the operating mode objects or the forced object is reset.

Additional information on the presence function / comfort extension

With presence detection, the room temperature controller can quickly switch over to a comfort extension upon push-button actuation using a presence button or, using a presence detector, switch to Comfort mode when movement by a person in the room is detected.

The "Presence detection" parameter enables the "Presence detection" parameter page. The remaining parameters can be set there.

In this regard, the parameter "Presence detection" determines whether presence detection is movement-controlled by a presence detector or done manually using a presence button:

- Presence detection by the presence button

The 1-bit communication object "Presence detection - Presence button" is enabled. An "ON" telegram to this object makes it possible to switch to the comfort extension if Night or Frost/heat protection mode (not activated by the "Window status" object!) is active. The extension will be automatically deactivated as soon as the configured "Length of comfort extension" time has elapsed. A comfort extension can be deactivated in advance if an "OFF" telegram is received via the object of the presence button. You cannot re-trigger the extension time.

If you have set the length of comfort extension to "0" in the ETS, you cannot activate a comfort extension from the Night or Frost/heat protection mode. In this case, the operating mode will not be changed, although the presence function has been activated.

If the standby mode is active, actuation on a presence object value = "ON" allows a switchover to the Comfort mode. This will also be the case if you have configured the length of comfort extension to "0". Comfort mode will remain active as long as the presence function remains active, or until another operating mode is specified.

The presence function will always be deleted whenever a switchover to a different operating mode takes place, or after a forced operating mode has been deactivated (associated with KNX forced switchover). In the event of a device reset (power failure, ETS programming operation), an active presence function is always deleted.

- i** If, during an active comfort extension and with a frost/heat protection switchover being configured "via window status", a window is opened, then the controller will activate frost/heat protection immediately. The comfort extension remains active in the background and the configured time continues to elapse. If the time elapses and the window remains open, the presence is reset and

an appropriate telegram is sent to the bus. However, if the window is closed again before the time has elapsed, then the comfort extension is executed again with the remaining run time.

- Presence detection by the presence detector

Two 1-bit communication objects "Presence detection - Presence object" are enabled. With this objects it is possible to integrate presence detectors into room temperature control. If a movement is detected ("ON" telegram), the controller will switch to Comfort mode. In this connection, it is irrelevant what has been set by the switchover objects. Only a window contact or the KNX forced object are of higher priority.

Both objects form an "Or" link of two presence detectors. In larger rooms, the use of two presence detectors can be useful. As long as one of the two detectors detects a presence, the controller remains in Comfort mode.

After the delay time has elapsed in the presence detector after a detected movement ("OFF" telegram), the controller will return to the mode which was active before presence detection, or it will compensate the telegrams of the operating mode objects received during presence detection, respectively.

In the event of a device reset (power failure, ETS programming operation), an active presence function is always deleted. In this case, the presence detector must transmit a new "ON" telegram to the controller to activate the presence function.

Additional information on the window status and the automatic frost protection

The room temperature controller offers various options to switch to frost/heat protection mode. In addition to switching over by means of the corresponding operating mode switchover object, frost/heat protection can be activated by a window contact, or alternatively, the frost protection can be activated by an automatic temperature function. The window contact or the automatic function has higher priority. The "Frost/heat protection" parameter determines how the switchover to forced frost/heat protection takes place:

- Frost/heat protection switchover "via window contact (frost and heat protection)"

The 1-bit object "Window contact" is enabled. A telegram having the value of = "ON" (open window) and sent to this object will activate the frost/heat protection mode. If this is the case, the operating mode cannot be deactivated by the switchover objects (except for the KNX forced object) or the presence function. Only a telegram with the value = "OFF" (closed window) will reset the window status and deactivate the frost/heat protection mode. After this, the operating mode set before the opening of the window or that mode carried by the bus while the window was open will be activated.

You can optionally configure a delay for the evaluation of the window status. Such delay can make sense if short ventilation of the room by opening the window is not supposed to change the operating mode. The delay time is set by the "Delay time" parameter and can be between 1 and 255 minutes. The window status will only be changed and thus the frost/heat protection mode activated after this parameterized time has elapsed. A setting of "0" will effect

the immediate activation of the frost/heat protection mode when the window is open. The window status will be in effect in the heating and in the cooling mode. After a power failure or ETS programming operation, the window status is always inactive.

- Frost protection mode switchover "via temperature drop (frost protection only)"
For this setting, automatic switchover to the frost protection mode can be made at times, depending on the room temperature determined.
If there are no window contacts, this setting can prevent unnecessary heating up of a room when windows or external doors are open.
With this function, a quick temperature drop can be detected by measuring the actual temperature every 4 minutes as is the case when a window is open in the winter months, for example. You can use the "Temperature drop detection from" parameter to set the maximum temperature drop in K / 4 min for switching over to the frost protection mode. If the controller detects that the room temperature has changed by at least the configured temperature jump within four minutes, frost protection is activated. After the time specified by the "Frost protection period" parameter has elapsed, the controller again automatically switches to the operating mode which was set before frost protection or which was tracked during automatic operation. It is not possible to retrigger an elapsing frost protection period.
- i** An activated automatic frost protection is cancelled by a setpoint shift, a setpoint change or an increase in the room temperature by 1 Kelvin.
- i** The KNX override object has a higher priority than the automatic frost protection mode and can interrupt the latter.
- i** The automatic frost protection mode only acts on heating for temperatures below the setpoint temperature of the operating mode set. Thus, no automatic switchover to frost protection can take place at room temperatures in the deadband or in the active cooling mode if the "Heating and cooling" operation is on. Automatic heat protection activation is not intended with this parameterization.
- i** Frequent draughts in a room can cause unintentional activation/deactivation of frost protection when the automatic frost protection mode is active and if the set temperature decrease is too low. Therefore switching into the frost/heat protection mode by window contacts should generally be preferred to the automatic option.

Setpoint temperature presetting

Setpoint temperatures can be specified for each operating mode in the ETS as part of configuration. It is possible to configure the setpoints for the "Comfort", "Standby" and "Night" modes directly (absolute setpoint presetting) or relatively (derivation from basic setpoint). The setpoint temperatures can later be adapted during regular operation by KNX communication objects if desired.

- i** The "Frost/heat protection" operating mode allows the separate configuration of two temperature setpoints for heating (frost protection) and cooling (heat protection) solely in the ETS. These temperature values cannot be changed later during controller operation.

The "Setpoint presetting" parameter defines the way in which the setpoint temperature is preset...

- Setting "relative"
When presetting the set-temperatures for Comfort, Standby and Night mode, attention has to be paid to the fact that all setpoints depend on each other as all values are derived from the basic temperature (basic setpoint). The "Basic setpoint temperature" parameter is used to specify the basic setpoint that is loaded as the default value when the device is programmed by the ETS. Taking into account the "Standby" and "Night" parameters under the header "Temperature shift via operating mode", the temperature setpoints for the standby and night mode are derived from this value depending on the heating or cooling operating mode. The deadband will be additionally considered for the "Heating and cooling" operating mode.
The 2-byte object "Basic setpoint" provides the option of changing the basic temperature, and thus all the dependent setpoint temperatures during device operation. A change via the object must always be enabled in the ETS by configuring the parameter "Approve activations via bus" to "yes". If the basic setpoint adjustment via the bus is disabled, the "Basic setpoint" object will be hidden. The controller rounds the temperature values received via the object to the specified "Step width of the setpoint shift" (0.1 K or 0.5 K).
 - Setting "absolute"
The setpoint temperatures for Comfort, Standby and Night mode are independent of each other. Depending on the operating mode and heating/cooling mode, various temperature values can be specified in the ETS within the range +7.0 °C to +40.0 °C. The ETS does not validate the temperature values. It is thus possible, for example, to select smaller setpoint temperatures for cooling mode than for heating mode, or to specify lower temperatures for Comfort mode than for Standby mode.
After commissioning using the ETS the setpoint temperatures can be changed via the bus by means of temperature telegrams. This can be done using the communication object "Setpoint temperature - Active operating mode". When the controller receives a telegram via this object, it immediately sets the received temperature as the new setpoint of the active operating mode, and operates from then on with this setpoint. In this manner it is possible to adapt the setpoint temperatures of all operating modes separately for heating and cooling mode. The frost or heat protection temperature programmed using the ETS cannot be changed in this manner.
- i** With absolute setpoint presetting there is no basic setpoint and, in the mixed operating mode "Heating and cooling" (if necessary also with additional level), also no deadband. Consequently, the room temperature controller cannot control the switchover of the operating mode automatically, which is why, in this

configuration, the setting for the parameter "Heating/cooling switchover" is fixed in the ETS to "via object".

Furthermore, setpoint shifting does not exist for absolute setpoint presetting.

- i** In two-level control mode, all set-temperatures of the additional level are derived from the setpoint temperatures of the basic level. The setpoint temperature of the additional level are determined by subtracting the "Difference between basic and additional levels", which is permanently configured in the ETS, from the setpoints of the basic level in heating mode or by adding the setpoints in cooling mode. If the temperature setpoints of the basic level are changed, the setpoint temperatures of the additional level will be automatically changed as well. Both levels will heat or cool with the same command value at the same time when the level distance is "0".

The temperature setpoints programmed in the room temperature controller by the ETS during commissioning can be changed via communication objects. In the ETS, the parameter "Overwrite setpoints in the device during ETS programming" can be used to determine whether the setpoints that are present in the device and may have been subsequently changed are overwritten during an ETS programming operation and thus replaced again by the values configured in the ETS. If this parameter is "Yes", then the setpoint temperatures are deleted in the device during a programming operation and replaced by the values of the ETS. If this parameter is configured to "No", then setpoints present in the device remain unchanged. The setpoint temperatures entered in the ETS then have no significance.

- i** During initial commissioning of the device the parameter "Overwrite setpoints in device during ETS programming" must be set to "yes" in order to perform valid initialisation of the memory slots in the device. The setting "Yes" is also necessary if essential controller properties (operating mode, setpoint specification, etc.) are changed in the ETS through new parameter configurations.

Setpoint temperatures for relative setpoint presetting

Depending on the operation, different cases should be distinguished when specifying the relative setpoint temperature, which then have an impact on the temperature derivation from the basic setpoint.

Setpoints for operation "Heating"

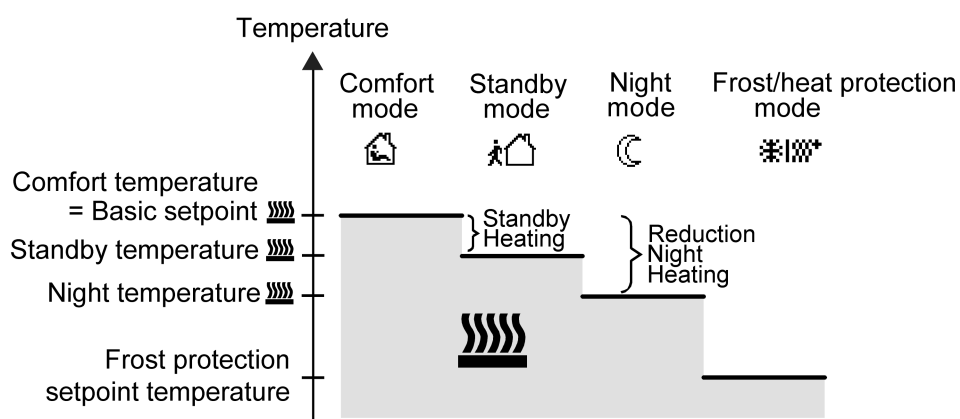

Figure 22: Setpoint temperatures in the operation "Heating"

The setpoint temperatures for Comfort, Standby and Night mode exist in this operation and the frost protection temperature can be preset (see figure 22). The following applies...

$$T_{\text{Standby setpoint heating}} \leq T_{\text{Comfort setpoint heating}}$$

or

$$T_{\text{Night setpoint heating}} \leq T_{\text{Comfort setpoint heating}}$$

The Standby and Night setpoint temperatures are derived from the reduction temperatures configured in the ETS from the comfort setpoint temperature (basic setpoint). The frost protection is supposed to prevent the heating system from freezing. For this reason, the frost protection temperature (default: +7 °C) should be set to a lower value than the night temperature. In principle, however, it is possible to select frost protection temperature values between +7.0 °C and +40.0 °C. The possible range of values for a setpoint temperature is bounded by the frost protection temperature in the lower range.

The level offset configured in ETS will be additionally considered in a two-level heating mode (see figure 23).

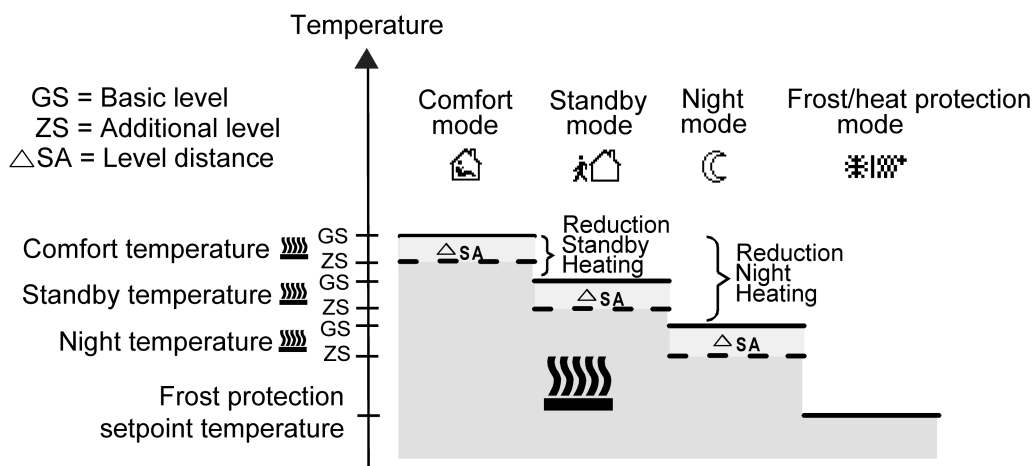

Figure 23: Setpoint temperatures in the operation "Basic and additional heating"

$$T_{\text{Comfort setpoint additional level heating}} \leq T_{\text{Comfort setpoint basic level heating}}$$

$$T_{\text{Standby setpoint additional level heating}} \leq T_{\text{Standby setpoint basic level heating}}$$

$$T_{\text{Standby setpoint heating}} \leq T_{\text{Comfort setpoint heating}}$$

or

$$T_{\text{Comfort setpoint additional level heating}} \leq T_{\text{Comfort setpoint basic level heating}}$$

$$T_{\text{Night setpoint additional level heating}} \leq T_{\text{Night setpoint basic level heating}}$$

$$T_{\text{Night setpoint heating}} \leq T_{\text{Comfort setpoint heating}}$$

Setpoints for the "cooling" operation

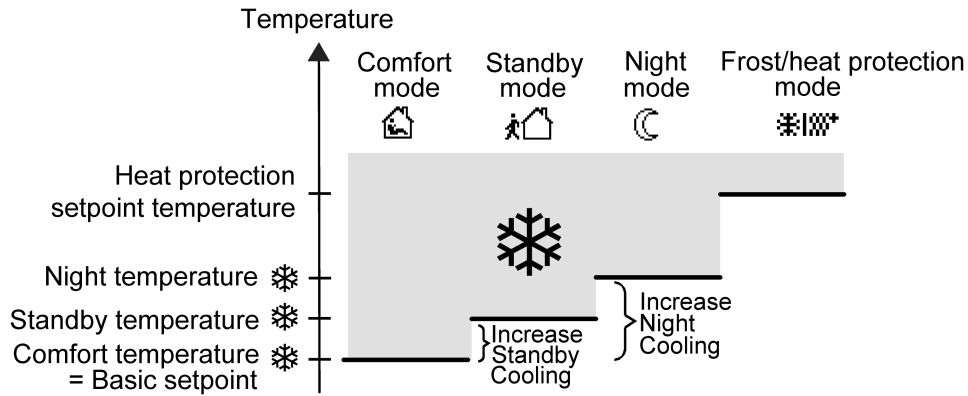

Figure 24: Setpoint temperatures in the operation "Cooling"

The setpoint temperatures for Comfort, Standby and Night mode exist in this operation and the heat protection temperature can be preset (see figure 24). The following applies...

$$T_{\text{Comfort setpoint cooling}} \leq T_{\text{Standby setpoint cooling}}$$

or

$$T_{\text{Comfort setpoint cooling}} \leq T_{\text{Night setpoint cooling}}$$

The standby and night set-temperatures are derived after the parameterized increase-temperatures from the comfort setpoint temperature (basic setpoint). The heat protection is intended to ensure that the temperature does not exceed the maximum permissible room temperature in order to protect system components. For this reason, the heat protection temperature (default: +35 °C) should be set to a higher value than the night temperature. In principle, however, it is possible to select heat protection temperature values between +7.0 °C and +45.0 °C. The possible range of values for a setpoint temperature is bounded by the heat protection temperature in the upper range.

The level offset configured in ETS will be additionally considered in a two-level cooling mode (see figure 25).

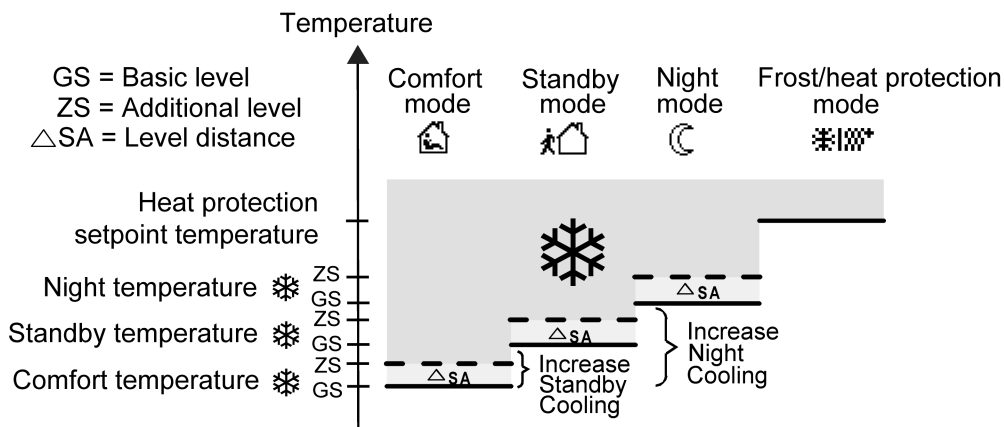

Figure 25: Setpoint temperatures in the operation "Basic and additional cooling"

$$T_{\text{Comfort setpoint basic level cooling}} \leq T_{\text{Comfort setpoint additional level cooling}}$$

$$T_{\text{Standby setpoint basic level cooling}} \leq T_{\text{Standby setpoint additional level cooling}}$$

$$T_{\text{Comfort setpoint cooling}} \leq T_{\text{Standby setpoint cooling}}$$

or

$$T_{\text{Comfort setpoint basic level cooling}} \leq T_{\text{Comfort setpoint additional level cooling}}$$

$$T_{\text{Night setpoint basic level cooling}} \leq T_{\text{Night setpoint additional level cooling}}$$

$$T_{\text{Comfort setpoint cooling}} \leq T_{\text{Night setpoint cooling}}$$

Setpoints for the "heating and cooling" operation

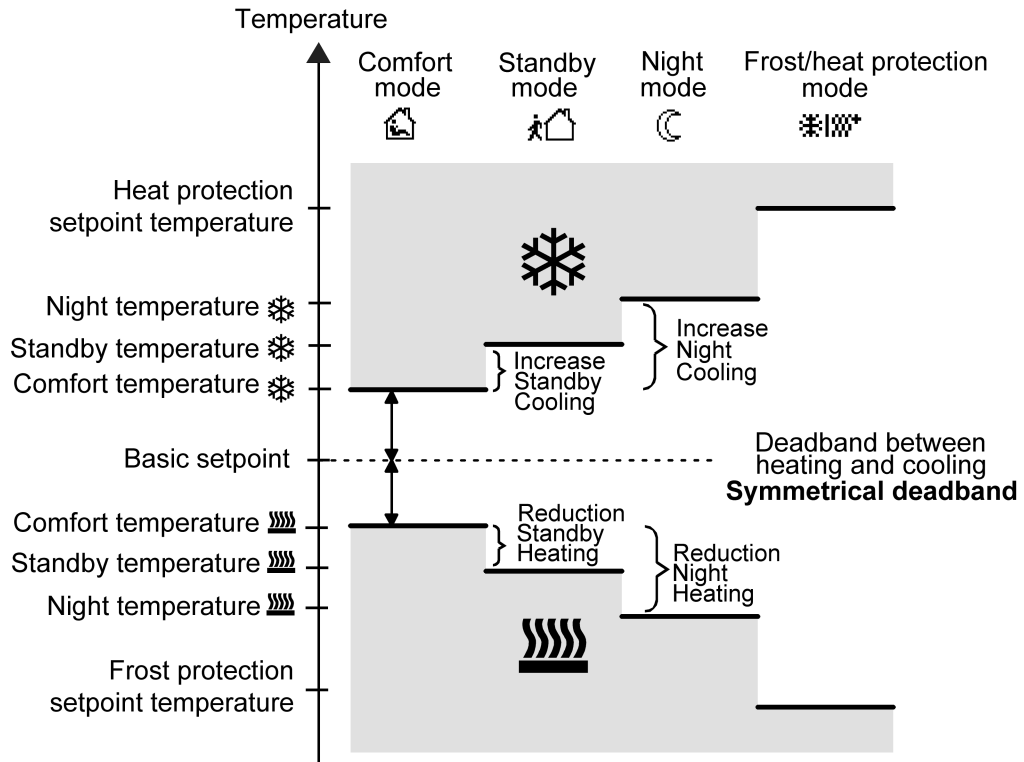

Figure 26: Setpoint temperatures in the operation "Heating and cooling" with symmetrical deadband

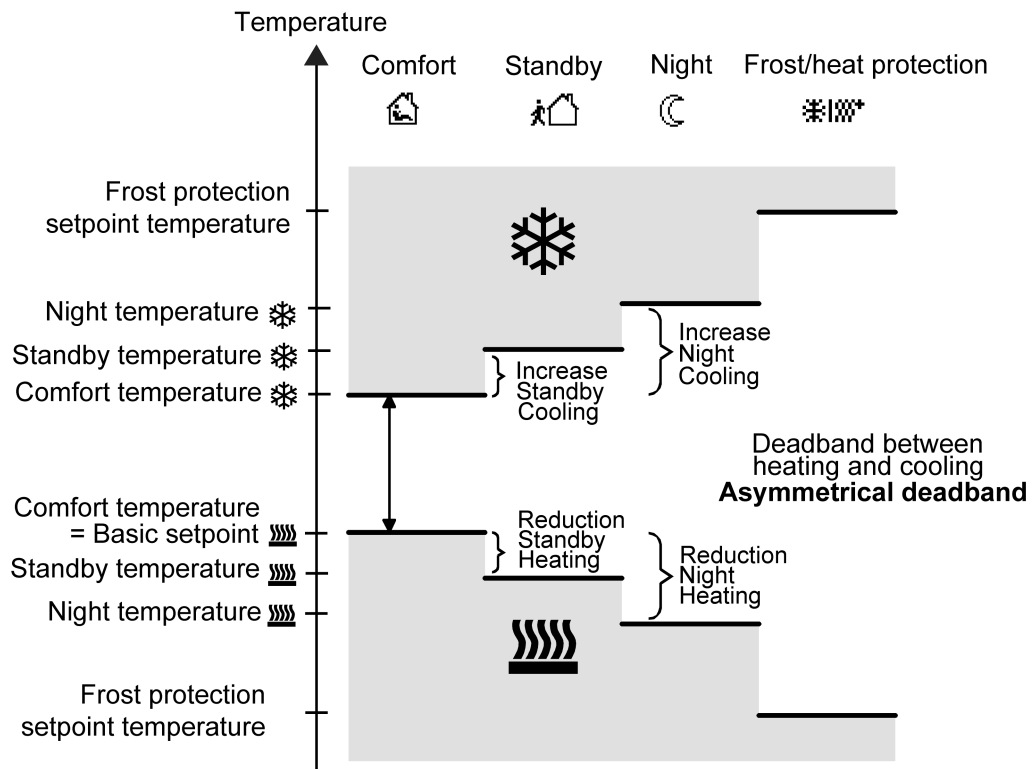

Figure 27: Setpoint temperatures in the operation "Heating and cooling" with asymmetrical deadband

For this heating/cooling operation, the setpoint temperatures of both heating/cooling modes exist for the Comfort, Standby and Night operation as well as the deadband. A distinction is made in the deadband position with combined heating and cooling. A symmetrical (see figure 26) or an asymmetrical (see figure 27) deadband position can be configured. In addition, the frost protection and the heat protection temperatures can be preset.

The following applies...

$$T_{\text{Standby setpoint heating}} \leq T_{\text{Comfort setpoint heating}} \leq T_{\text{Comfort setpoint cooling}} \leq T_{\text{Standby setpoint cooling}}$$

or

$$T_{\text{Night setpoint heating}} \leq T_{\text{Comfort setpoint heating}} \leq T_{\text{Comfort setpoint cooling}} \leq T_{\text{Night setpoint cooling}}$$

The standby and night setpoint temperatures are derived from the comfort setpoint temperatures for heating or cooling. The temperature increase (for cooling) and the temperature decrease (for heating) of both operating modes can be preset in ETS. The comfort temperatures themselves are derived from the deadband and the basic setpoint. The frost protection is supposed to prevent the heating system from freezing. For this reason, the frost protection temperature (default: +7 °C) should be set to a lower value than the night temperature for heating. In principle, however, it is possible to select frost protection temperature values between +7.0 °C and +40.0 °C. The heat protection is intended to prevent the temperature from exceeding the maximum permissible room temperature in order to protect system components. For this reason, the heat protection temperature (default: +35 °C) should be set to a higher value than the night temperature for cooling. In principle, however, it is possible to select heat protection temperature values between +7.0 °C and +45.0 °C. The pos-

sible range of values for a setpoint temperature for "heating and cooling" lies between +7.0 °C and +45.0 °C and is bounded by the frost protection temperature in the lower range and by the heat protection temperature in the upper range.

The level offset configured in ETS will be additionally considered in a two-level heating or cooling mode.

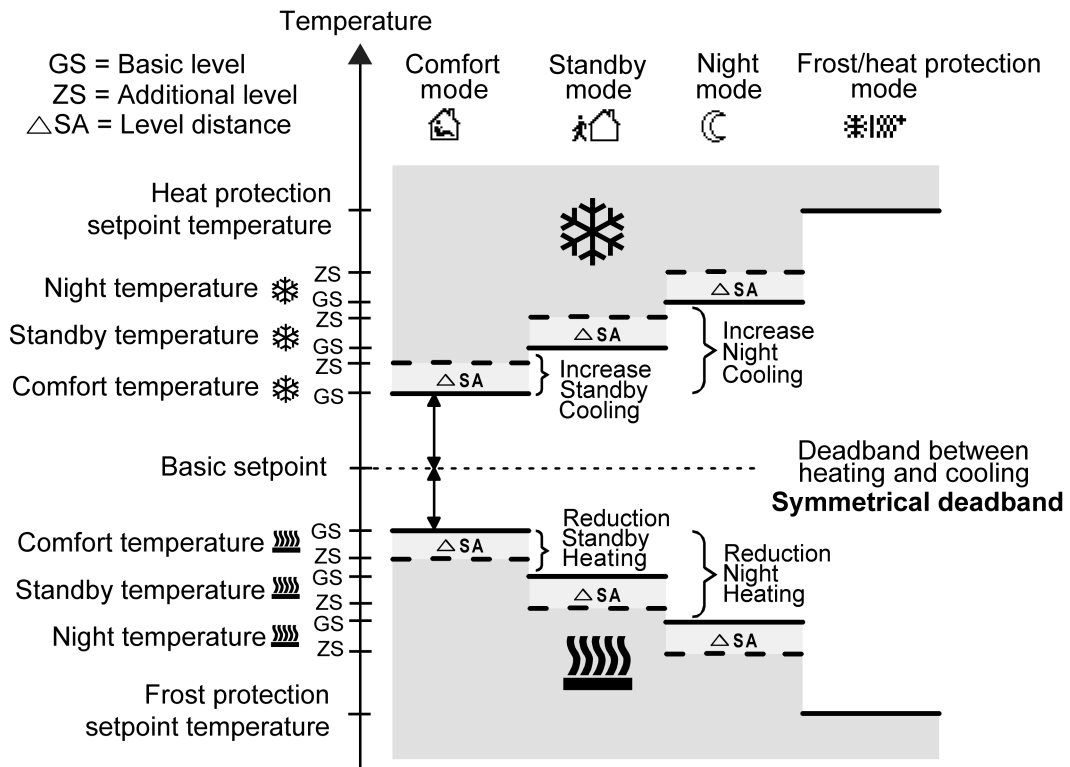

Figure 28: Setpoint temperatures in the operation "Basic and additional heating and cooling" with symmetrical deadband

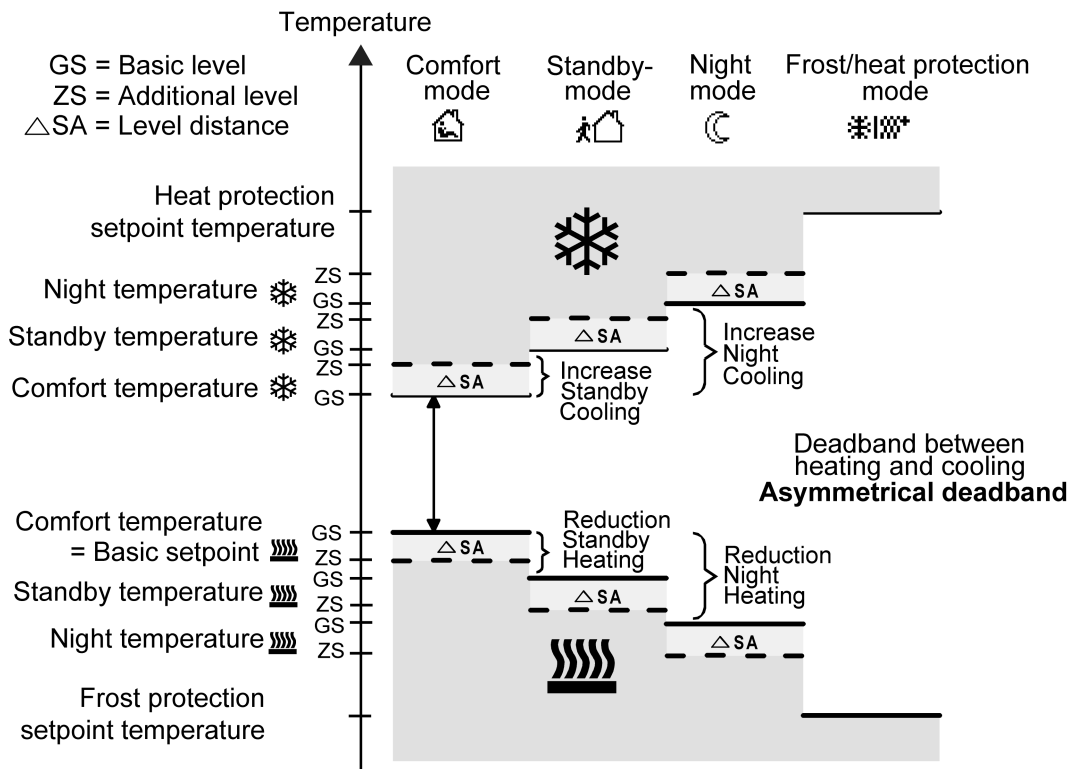

Figure 29: Setpoint temperatures in the operation "Basic and additional heating and cooling" with asymmetrical deadband

$$T_{\text{Comfort setpoint add. level Heating}} \leq T_{\text{Comfort setpoint basic level Heating}} \leq T_{\text{Comfort setpoint basic level Cooling}} \leq T_{\text{Comfort setpoint add. level Cooling}}$$

$$T_{\text{Standby setpoint add. level Heating}} \leq T_{\text{Standby setpoint basic level Heating}} \leq T_{\text{Standby setpoint basic level Cooling}} \leq T_{\text{Standby setpoint add. level Cooling}}$$

$$T_{\text{Standby setpoint heating}} \leq T_{\text{Comfort setpoint heating}} \leq T_{\text{Comfort setpoint cooling}} \leq T_{\text{Standby setpoint cooling}}$$

or

$$T_{\text{Comfort setpoint add. level Heating}} \leq T_{\text{Comfort setpoint basic level Heating}} \leq T_{\text{Comfort setpoint basic level Cooling}} \leq T_{\text{Comfort setpoint add. level Cooling}}$$

$$T_{\text{Night setpoint add. level Heating}} \leq T_{\text{Night setpoint basic level Heating}} \leq T_{\text{Night setpoint basic level Cooling}} \leq T_{\text{Night setpoint add. level Cooling}}$$

$$T_{\text{Night setpoint heating}} \leq T_{\text{Comfort setpoint heating}} \leq T_{\text{Comfort setpoint cooling}} \leq T_{\text{Night setpoint cooling}}$$

i In the case of switching 2-point feedback control, the hysteresis values must additionally be taken into account!

Deadband and deadband positions in the combined heating and cooling operation

With relative setpoint presetting, the comfort setpoint temperatures for heating and cooling are derived from the basic setpoint in consideration of the set deadband. The deadband (temperature zone for which there is neither heating nor cooling) is the difference between the comfort setpoint temperatures. This deadband does not exist for absolute setpoint presetting.

The parameters "Deadband between heating and cooling", "Allocation of deadband" and "Basic setpoint temperature" are specified in the ETS configuration. One distinguishes between the following settings...

- Allocation of deadband = "symmetrical"
The deadband preset in the ETS is divided into two parts at the basic setpoint. Based on the resulting half deadband, the comfort setpoint temperatures are derived directly from the basic setpoint.

The following applies...

$$T_{\text{Basic setpoint}} - \frac{1}{2}T_{\text{Deadband}} = T_{\text{Comfort setpoint heating}}$$

and

$$T_{\text{Basic setpoint}} + \frac{1}{2}T_{\text{Deadband}} = T_{\text{Comfort setpoint cooling}}$$

$$\rightarrow T_{\text{Comfort setpoint cooling}} - T_{\text{Comfort setpoint heating}} = T_{\text{Deadband}}$$

$$\rightarrow T_{\text{Comfort setpoint cooling}} \geq T_{\text{Comfort setpoint heating}}$$

- Allocation of deadband = "asymmetrical"
With this setting the comfort setpoint temperature for heating equals the basic setpoint! The deadband preset in the ETS is effective only from the basic setpoint in the direction of comfort temperature for cooling. Thus the comfort setpoint temperature for cooling is derived directly from the comfort setpoint for heating.

The following applies...

$$T_{\text{Basic setpoint}} = T_{\text{Comfort setpoint heating}}$$

$$\rightarrow T_{\text{Basic setpoint}} + T_{\text{Deadband}} = T_{\text{Comfort setpoint cooling}}$$

$$\rightarrow T_{\text{Comfort setpoint cooling}} - T_{\text{Comfort setpoint heating}} = T_{\text{Deadband}}$$

$$\rightarrow T_{\text{Comfort setpoint cooling}} \geq T_{\text{Comfort setpoint heating}}$$

11.1.2.1 Operating mode and setpoint parameters

FanCoil with controller -> Heating control -> General -> Setpoints

Overwrite setpoints in device during ETS programming operation	Active Inactive
The setpoint temperatures programmed in the room temperature controller by the ETS during commissioning can be changed via communication objects. This parameter can be used to define whether the setpoints present in the device, which may have been changed subsequently, are overwritten during an ETS programming operation and thus replaced again by the values parameterised in the ETS. If this parameter is "Active", then the setpoint temperatures are deleted in the device during a programming operation and replaced by the values of the ETS. If this parameter is configured to "Inactive", then setpoints present in the device remain unchanged. The setpoint temperatures entered in the ETS then have no significance.	

Setpoint presetting	absolute relative
It is possible to configure the setpoints for the "Comfort", "Standby" and "Night" modes directly (absolute setpoint presetting) or relatively (derivation from basic setpoint). This parameter defines the way the setpoint temperature is preset. With "Relative": All temperature setpoints are derived from the basic temperature (basic setpoint). With "Absolute": The setpoint temperatures are independent of each other. Different temperature values can be specified for each operating mode and heating/cooling mode.	

Setpoint temperatures via operating mode for absolute setpoint presetting

Heating

Comfort	7 ... 21.0 ... 40 °C
With absolute setpoint presetting the setpoint temperatures for Comfort, Standby and Night mode are independent of each other. Depending on the operating mode and heating/cooling mode, various temperature values can be specified in the ETS within the range +7.0 °C to +40.0 °C. The ETS does not validate the temperature values. It is thus possible, for example, to select smaller setpoint temperatures for cooling mode than for heating mode, or to specify lower temperatures for Comfort mode than for Standby mode. After commissioning using the ETS the setpoint temperatures can be changed via the bus by means of temperature telegrams. This can be done using the communication object "Setpoint temperature - Active operating mode". Presetting of the setpoint temperature for the Comfort heating mode. These parameters are only visible with absolute setpoint presetting!	
Standby	7 ... 19.0 ... 40 °C
Presetting of the setpoint temperature for heating standby mode.	

Night	7 ... 17.0 ... 40 °C
Presetting of the setpoint temperature for heating night mode.	

Frost protection	7.0 ... 40 °C
Presetting of the setpoint temperature for heating frost protection mode.	

Cooling

Comfort	7 ... 23.0 ... 40 °C
Presetting of the setpoint temperature for cooling standby mode.	

Standby	7 ... 25.0 ... 40 °C
Presetting of the setpoint temperature for cooling standby mode.	

Night mode	7 ... 27.0 ... 40 °C
Presetting of the setpoint temperature for cooling night mode.	

Heat protection	7 ... 35.0 ... 45 °C
Presetting of the setpoint temperature for cooling heat protection mode.	

Accept change permanently via bus	Active Inactive
-----------------------------------	--------------------

One has to distinguish between two cases, defined by this parameter, if the setpoint is changed by the object. This parameter is only visible with absolute setpoint pre-setting!

When "Active": If, with this setting, the setpoint temperature is adjusted, the controller saves the value permanently to the permanent storage. The newly adjusted value will overwrite the initial value, i.e. the absolute setpoint temperature originally loaded using the ETS. The changed values are also retained after a device reset, after a switchover of the operating mode or after a switchover of the operating mode (with absolute setpoint specification individually for each operating mode for heating and cooling).

When "Inactive": The setpoints received via the object remain active only temporarily. In case of a bus voltage failure, after a switchover to another operating mode (e. g. Comfort to Standby, or also Comfort to Comfort), or after a switchover of the operating mode (e. g. Heating to Cooling), the last setpoint changed will be discarded and replaced by the initial value.

Difference between basic and additional level	0 ...2...12.7 K
---	-----------------

In a two stage control mode it is necessary to determine the temperature difference to the basic stage with which the additional stage is to be incorporated into the control. This parameter defines the level spacing.

The parameter can only be seen in two-level control operation.

Setpoint temperatures via operating mode for relative setpoint presetting

Basic setpoint temperature	7 ... 21.0 ... 40 °C
<p>This parameter defines the temperature value to be applied as the basic setpoint after commissioning by the ETS. All the temperature setpoints are derived from the basic setpoint.</p> <p>This parameter is only visible with relative setpoint presetting!</p>	
Approve change via bus	Active Inactive
<p>Here, it is possible to specify if it is possible to change the basic setpoint via the bus. This parameter is only visible with relative setpoint presetting!</p>	
Accept permanently	Active Inactive
<p>In addition to specifying individual setpoint temperatures by the ETS or basic setpoint object, the user can shift the basic setpoint in a specific range via a communication object. Whether a basic setpoint shifting only affects the currently active operating mode or whether it influences all other setpoint temperatures of the remaining operating modes is determined by this parameter.</p> <p>In the "Active" setting, the shift of the basic setpoint carried out affects all operating modes. The shift is maintained even after a switchover of the operating mode or the heating/cooling mode or adjusting the basic setpoint. The changed values are also retained after a device reset, after a switch-over of the operating mode or after a switch-over of the heating/cooling mode.</p> <p>In the "inactive" setting, the basic setpoint shift carried out takes effect for only as long as the operating mode is not changed or the basic setpoint is maintained. Otherwise the setpoint shift will be reset to "0".</p> <p>This parameter is only visible with relative setpoint presetting!</p>	

Temperature shift via operating mode for relative setpoint presetting

Heating

Standby	-10...-2...0 K
<p>The value by which the standby setpoint temperature for heating is lowered compared to the heating comfort temperature.</p> <p>The parameter is only visible in the "Heating" or "Heating and cooling" operating mode (if necessary with additional levels) and only with relative setpoint presetting.</p>	
Night	-10...-4...0 K
<p>The value by which the night temperature for heating is lowered compared to the heating comfort temperature.</p> <p>The parameter is only visible in the "Heating" or "Heating and cooling" operating mode (if necessary with additional levels) and only with relative setpoint presetting.</p>	

Frost protection	7.0 ... 40 °C
This parameter specifies the setpoint temperature for frost protection. The parameter is only visible in "Heating" or "Heating and cooling" operating modes (if necessary with additional levels).	

Cooling

Standby	0...20...10 K
The value by which the standby setpoint temperature for cooling is raised compared to the cooling comfort temperature. The parameter is only visible in the "Cooling" or "Heating and cooling" operating mode (if necessary with additional levels) and only with relative setpoint presetting.	

Night mode	0...4...10 K
The value by which the night temperature for cooling is raised compared to the cooling comfort temperature. The parameter is only visible in the "Cooling" or "Heating and cooling" operating mode (if necessary with additional levels) and only with relative setpoint presetting.	

Heat protection	7 ... 35, ... 45 °C
This parameter specifies the setpoint temperature for heat protection. The parameter is only visible in "Cooling" or "Heating and cooling" operating modes (if necessary with additional levels).	

Difference between basic and additional level	0...2...12.7 K
In a two stage control mode it is necessary to determine the temperature difference to the basic stage with which the additional stage is to be incorporated into the control. This parameter defines the level spacing. The parameter can only be seen in two-level control operation.	

Setpoint temperature shift

Maximum shift upwards	0 K + 1 K + 2 K + 3 K + 4 K + 5 K + 6 K + 7 K + 8 K + 9 K + 10 K
This is used to define the maximum range in which the basic setpoint temperature can be adjusted upwards. This parameter is only visible with relative setpoint presetting!	

Maximum shift downwards	0 K - 1 K - 2 K - 3 K - 4 K - 5 K - 6 K - 7 K - 8 K - 9 K - 10 K
<p>This is used to define the maximum range in which the basic setpoint temperature can be adjusted downwards.</p> <p>This parameter is only visible with relative setpoint presetting!</p>	
Type of shift	Via counter value x step width Via relative temperature value
<p>Depending on the setting of the parameter "Type of shift", the shift takes place via a 2-byte communication object according to KNX DPT 9.002 or via a 1-byte communication object according to KNX DPT 6.010.</p> <p>This parameter is only visible with relative setpoint presetting!</p>	
Accept changes permanently via bus	Active Inactive
<p>In addition to specifying individual setpoint temperatures by the ETS or basic setpoint object, the user can shift the basic setpoint in a specific range using the sensor buttons or a communication object. Whether a basic setpoint shifting only affects the currently active operating mode or whether it influences all other setpoint temperatures of the remaining operating modes is determined by this parameter.</p> <p>In the "Active" setting, the shift of the basic setpoint carried out affects all operating modes. The shift is maintained even after a switchover of the operating mode or the heating/cooling mode or adjusting the basic setpoint.</p> <p>In the "inactive" setting, the basic setpoint shift carried out takes effect for only as long as the operating mode is not changed or the basic setpoint is maintained. Otherwise the setpoint shift will be reset to "0".</p>	

Value adjustment

Increment	0.1 K 0.5 K
<p>This parameter defines the value of a level of the setpoint shift. With a setpoint shift, the basic setpoint (with relative setpoint specification) is changed by the temperature value configured here when there is an adjustment by one step in a positive or negative direction. The controller module rounds the temperature values received via the "Setpoint temperature - Basic value" object and matches the values to the step width configured here.</p> <p>The parameter is only available if the shift has the setting "Via counter value x step width".</p> <p>In combination with the function "Setpoint heating temperature increase", the setpoint temperature can also be modified in smaller steps, even with a step width of 0.5 K.</p>	

Deadband between heating and cooling

Allocation of deadband	symmetrical asymmetrical
<p>With relative setpoint presetting, the comfort setpoint temperatures for the operating mode "Heating and cooling" are derived from the basic setpoint in consideration of the set deadband. The deadband (temperature zone for which there is neither heating nor cooling) is the difference between the comfort setpoint temperatures.</p> <p>Symmetrical setting: The deadband preset in the ETS plug-in is divided in two parts at the basic setpoint. Based on the resulting half deadband, the comfort setpoint temperatures are derived directly from the basic setpoint (Basic setpoint - 1/2 deadband = Heating comfort temperature or Basic setpoint + 1/2 deadband = Cooling comfort temperature).</p> <p>Asymmetrical setting: With this setting the comfort setpoint temperature for heating equals the basic setpoint! The preset deadband is effective only from the basic setpoint in the direction of comfort temperature for cooling. Thus the comfort setpoint temperature for cooling is derived directly from the comfort setpoint for heating.</p> <p>The parameter is only visible in the "Heating and cooling" operating mode (if necessary with additional levels) and only with relative setpoint presetting!</p>	
Size	0.1...1...25.5 K
<p>With relative setpoint presetting, the comfort setpoint temperatures for heating and cooling are derived from the basic setpoint in consideration of the set deadband. The deadband (temperature zone for which there is neither heating nor cooling) is the difference between the comfort setpoint temperatures. It is set using this parameter.</p> <p>The parameter is only visible in the "Heating and cooling" operating mode (if necessary with additional levels) and only with relative setpoint presetting.</p>	

Setpoint temperature transmission behaviour

on change by (0 = inactive)	0...0.1...25.5 K
Determines the size of the value change required to transmit the current value automatically to the bus via the "Setpoint temperature" object. In the "0" setting, the setpoint temperature is not transmitted automatically when there is a change.	
Cyclical (0 = inactive)	0...255 min
This parameter determines whether the setpoint temperature is to be transmitted cyclically via the "Setpoint temperature" object. Definition of the cycle time by this parameter. In the "0" setting, the setpoint temperature is not transmitted cyclically.	

Presence detection

FanCoil with controller -> Heating control -> General -> Approvals

Presence detection	Active Inactive
With presence detection, the room temperature controller can quickly switch over to a comfort extension upon push-button actuation using a presence button or, using a presence detector, switch to Comfort mode when movement by a person in the room is detected. If this parameter is activated, further parameters will become visible.	

FanCoil with controller -> Heating control -> General -> Presence detection

Presence detection	Presence button Presence detector
<p>Presence button: The 1-bit communication object "Presence detection - Presence button" is enabled. An "ON" telegram to this object makes it possible to switch to the comfort extension if night or frost/heat protection mode is active.</p> <p>Presence detector: Two 1-bit communication objects "Presence detection - presence object" are enabled. With this objects it is possible to integrate presence detectors into room temperature control. If a movement is detected ("ON" telegram), the controller will switch to Comfort mode. Both objects form an "Or" link of two presence detectors. In larger rooms, the use of two presence detectors can be useful. As long as one of the two detectors detects a presence, the controller remains in Comfort mode</p>	
Length of the comfort extension (0 = inactive)	0 ... 30 ... 255 min
This parameter can be used to set the duration of a comfort extension by means of a presence object. A comfort extension can be deactivated in advance if an "OFF" telegram is received via the object of the presence button. You cannot re-trigger the extension time	

11.1.2.2 Objects for operating mode and setpoints

Function	Name	Type	DPT	Flag
Operating mode - Pre-set	RTC ... -Input	1-byte	20,102	C, -, W, T, U
<p>1-byte object for change-over of the operating mode of the controller according to the KNX specification.</p> <p>After the mains voltage returns or an ETS programming operation, the current operating mode is transmitted by means of this object.</p>				
Function	Name	Type	DPT	Flag
Operating mode - Forced	RTC ... -Input	1-byte	20,102	C, -, W, T, U
<p>1-byte object for forced change-over (highest priority) of the operating mode of the controller according to the KNX specification.</p>				
Function	Name	Type	DPT	Flag
Presence detection - Presence button	RTC ... -Input	1-bit	1,001	C, -, W, T, U
<p>1-bit object through which an external presence button (e. g. from a controller extension) can be linked to the controller (polarity: Presence exists = "1", no presence exists = "0").</p> <p>Presence allows permanent switching to Comfort mode (starting in Standby mode) or temporary switching to this comfort extension (starting from Night mode or Frost/heat protection mode).</p> <p>Presence in Standby mode: If there is a presence, the controller activates Comfort mode. As soon as the object no longer signals a presence, the controller switches back to Standby mode.</p> <p>Presence in Night mode or Frost/heat protection mode: If there is a presence, the controller activates the comfort extension. After the configured length of the comfort extension has elapsed, the system automatically switches back to Night mode or Frost/heat protection mode. In this case, the object value is reset automatically.</p> <p>After the mains voltage returns or an ETS programming operation (controller reset), the presence function is always inactive.</p> <p>This object is only visible when presence detection is configured to "Presence button".</p>				

Function	Name	Type	DPT	Flag
Presence detection - Presence object 1	RTC ... -Input	1-bit	1,001	C, -, W, -, U
Presence detection - Presence object 2	RTC ... -Input	1-bit	1,001	C, -, W, -, U

1-bit object through which an external KNX presence detector can be linked to the controller (polarity: Presence exists = "1", no presence exists = "0").

If there is a presence, the controller activates Comfort mode, provided that no higher-level function (e. g. window status) is active. The controller switches to the last specified operating mode as soon as the presence detector ceases to signal a presence.

After the mains voltage returns or an ETS programming operation (controller reset), the presence function is always inactive.

These objects are only visible when presence detection is configured to "Presence detector".

Function	Name	Type	DPT	Flag
Frost/heat protection - Window contact	RTC ... -Input	1-bit	1,019	C, -, W, -, U

1-bit object for the coupling of window contacts.

Polarity: Window open = "1", window closed = "0".

Function	Name	Type	DPT	Flag
Frost protection - Tem- perature drop - Status	RTC ... - Output	1-bit	1,011	C, R, -, T, A

1-bit object to signal a detected temperature drop.

Polarity: temperature drop detected = "1", no temperature drop detected = "0".

Function	Name	Type	DPT	Flag
Setpoint temperature - Active operating mode - Status	RTR ... - Output	2-byte	9,001	C, R, -, T, A

2-byte object for the output of the current temperature setpoint. Depending on the operation, the possible range of values is limited by the configured frost protection and/or heat protection temperature.

The temperature value is always output in the format "°C".

After the mains voltage returns or an ETS programming operation (controller reset), the current setpoint temperature is transmitted via this object.

Function: absolute setpoint temperature specification

Function	Name	Type	DPT	Flag
Setpoint temperature - Active operating mode	RTR ... - Input	2-byte	9,001	C, -, W, -, U

2-byte object for external setting of a setpoint for absolute setpoint presetting. Depending on the operation, the possible range of values is limited by the configured frost protection and/or heat protection temperature. The controller rounds the temperature values received via the object to 0.1 K.

The temperature value must always be specified in the format "°C".

Function: relative setpoint temperature specification, basic value

Function	Name	Type	DPT	Flag
Setpoint temperature - Basic value	RTR ... - Input	2-byte	9,001	C, -, W, -, U

2-byte object for external specification of the basic setpoint for relative setpoint specification. Depending on the operation, the possible range of values is limited by the configured frost protection and/or heat protection temperature. The controller rounds the temperature values received irrespective of the configured value of the of the setpoint shift (0.1 K or 0.5 K).

The temperature value must always be specified in the format "°C".

Function	Name	Type	DPT	Flag
Setpoint temperature - Basic value - Status	RTR ... - Output	2-byte	9,001	C, R, -, T, A

2-byte object for the output of the current basic setpoint. Depending on the operation, the possible range of values is limited by the configured frost protection and/or heat protection temperature.

The temperature value is always output in the format "°C".

After the mains voltage returns or an ETS programming operation (controller reset), the current basic setpoint temperature is transmitted via this object.

Function: relative setpoint temperature shift via direct temperature value

Function	Name	Type	DPT	Flag
Setpoint temperature - Shift	RTR ... - Input	2-byte	9,002	C, -, W, -, U

2-byte object for setting a basic setpoint shifting, e. g. via a controller extension. The value of a counter value in the communication object is dependent on the configured setpoint shift value (0.1 K or 0.5 K). The value "0" means that no shift is active . The value is depicted in a double complement in the positive and negative direction.

In case the limits of the value range are exceeded by the preset external value, the controller will automatically reset the received value to the minimum and maximum limits.

Function	Name	Type	DPT	Flag
Setpoint temperature - Shift - Status	RTR ... - Output	2-byte	9,002	C, R, -, T, A
<p>2-byte object for giving feedback on the current setpoint shift for evaluation, e. g. by a controller extension. The value "0" means that no shift is active . The value is depicted in a double complement in the positive and negative direction.</p> <p>After the mains voltage returns or an ETS programming operation (controller reset), the current value for the basic setpoint shift is transmitted via this object. Since the value for the basic setpoint shift is stored exclusively in a volatile memory, the shift is always "0" immediately after the mains voltage returns or an ETS programming operation.</p>				

Function: relative setpoint temperature shift via meter value ... Increment

Function	Name	Type	DPT	Flag
Setpoint temperature - Shift	RTR ... - Input	1-byte	6,010	C, R, -, T, A
<p>1-byte object for setting a basic setpoint shifting, e. g. via a controller extension. The value of a counter value in the communication object is dependent on the configured setpoint shift value (0.1 K or 0.5 K). The value "0" means that no shift is active . The value is depicted in a double complement in the positive and negative direction.</p> <p>In case the limits of the value range are exceeded by the preset external value, the controller will automatically reset the received value to the minimum and maximum limits.</p>				

Function	Name	Type	DPT	Flag
Setpoint temperature - Shift - Status	RTR ... - Output	1-byte	6,010	C, R, -, T, A
<p>1-byte object for giving feedback on the current setpoint shift for evaluation, e. g. by a controller extension. The value of a counter value in the communication object is dependent on the configured setpoint shift value (0.1 K or 0.5 K). The value "0" means that no shift is active . The value is depicted in a double complement in the positive and negative direction.</p> <p>After the mains voltage returns or an ETS programming operation (controller reset), the current value for the basic setpoint shift is transmitted via this object. Since the value for the basic setpoint shift is stored exclusively in a volatile memory, the shift is always "0" immediately after the mains voltage returns or an ETS programming operation.</p>				

11.1.3 Command value output and command value limit

Automatic transmission

On automatic transmission of the command value telegrams, a distinction is made with regard to the type of control...

- **Continuous PI control:**

In the case of continuous PI control, the room temperature controller calculates a new command value cyclically every 30 seconds and outputs it to the bus via a 1-byte value object. In doing so, the parameter "On change by (0 = inactive)" can be used to specify the change interval of the command value in percent, according to which a new command value is to be output to the bus. The change interval can be configured to "0" so that a change in the command value will not result in an automatic transmission.

In addition to the command value output following a change, the current command value may be periodically transmitted. In addition to the times when changes are to be expected, other command value telegrams will be output according to the active value after a configurable cycle time. This ensures that, during cyclical security monitoring of the command value in valve drive or in the addressed switch actuator, telegrams are received within the monitoring time. The time interval defined by the parameter "Cyclical (0 = inactive)" should correspond to the monitoring time in the actuator (cycle time in the controller is preferably to be configured smaller). The "0" setting will deactivate the periodic transmission of the command value.

With continuous PI control it must be noted that if the cyclical and the automatic transmission are both deactivated, no command value telegrams will be transmitted in case of a change!
- **Switching PI control (PWM):**

In case of a switching PI control (PWM), the room temperature controller calculates a new command value internally every 30 seconds. The parameter "PWM cycle time" defines the cycle time of the PWM command value signal.

If the command value is changed, the current PWM cycle is adapted as required so that the duty factor corresponds as directly as possible to the new command value. This adaptation is carried out in the same way as for activation of the valve outputs.
- **2-point feedback control:**

In case of a 2-point feedback control, the room temperature and thus the hysteresis values are evaluated periodically every 30 seconds, so that the command values, if required, will change solely during these times. As, with this control algorithm, no continuous command values are calculated, the parameter "On change by (0 = inactive)" has no effect with this control algorithm.

In addition to the command value output following a change, the current command value may be periodically transmitted on the bus. In addition to the times when changes are to be expected, other command value telegrams will be output according to the active value after a configurable cycle time. This ensures that, during cyclical security monitoring of the command value in valve drive or in the addressed switch actuator, telegrams are received within the monitoring time. The time interval defined by the parameter "Cyclical (0 = in-

active)" should correspond to the monitoring time in the actuator (cycle time in the controller is preferably to be configured smaller). The "0" setting will deactivate the periodic transmission of the command value.

Command value limit

Optionally a command value limit can be configured in the ETS. The command value limit allows the restriction of calculated command values to the range limits "Minimum command value" and "Maximum command value". The limits are permanently set in the ETS and, if command value limitation is active, can be neither undershot or exceeded during device operation. It is possible, if available, to specify various limiting values for the basic and additional stages and for heating and cooling.

The "Activation" parameter defines the type of action of the limiting function. The command value limit can either be activated or deactivated using the 1-bit communication object "Command value limit", or be permanently active. When controlling via the object, it is possible to have the controller activate the command value limit automatically after the bus voltage returns or after an ETS programming operation. Here, the "Active after reset" parameter defines the initialisation behaviour. In the "No" setting, the command value limit is not automatically activated after a device reset. A "1" telegram must first be received via the "Command value limit" object for the limit to be activated. In the "Yes" setting, the controller activates the command value limit automatically after a device reset. To deactivate the limit a "0" telegram must be received via the "Command value limit - Activate / Deactivate" object. The limit can be switched on or off at any time using the object.

With a permanently active command value limit, the initialisation behaviour cannot be configured separately after a device reset, as the limit is always active. In this case it is also not possible to configure any object.

As soon as the command value limit is active, calculated command values are limited according to the limiting values from the ETS. The behaviour with regard to the minimum or maximum command value is then as follows...

- Minimum command value:
The "Minimum command value" parameter specifies the lower command value limiting value. The setting can be made in 5% increments in the range 5% ... 50% can be made. With an active command value limit, the set minimum command value is not undershot by command values. If the controller calculates smaller command values, it sets the configured minimum command value. The controller transmits a 0% command value if no more heating or cooling energy has to be demanded.
- Maximum command value:
The "Maximum command value" parameter specifies the upper command value limiting value. The setting can be made in 5% increments in the range 55% ... 100% can be made. With an active command value limit, the set maximum command value is not exceeded. If the controller calculates larger command values, it sets the configured maximum command value.

If the limit is removed, the device automatically repositions the most recently calculated command value to the unlimited values when the next calculation interval for the command values (30 seconds) has elapsed.

- i** An active command value limit has a negative effect on the control result when the command value range is very restricted. A control deviation must be expected.

Special case for command value 100% (Clipping mode)

If with a PI control the calculated command value of the controller exceeds the physical limits of the actuator, in other words if the calculated command value is greater than 100%, then the command value is set to the maximum value (100%) and thus limited. This special, necessary control behaviour is also called "clipping". With PI control the command value can reach the value "100%" if there is a large deviation of the room temperature from the setpoint temperature or the controller requires a long time to adjust to the setpoint with the heating or cooling energy that is being applied. The controller evaluates this state in a particular manner.

The controller maintains the maximum command value only as long as it is necessary. After that it adjusts the command value downwards according to the PI algorithm. The advantage of this control characteristic is the fact that the room temperature does not exceed the setpoint temperature at all, or only slightly. It should be mentioned that this necessary control principle increases the tendency to oscillate about the setpoint.

- i** Clipping may also occur when a command value limit is active (maximum command value). In this case, if the internally calculated command value reaches 100%, then the controller only transmits to the bus the maximum command value according to the ETS configuration.

11.1.3.1 Command value output parameters

FanCoil with controller -> Heating control -> General -> Control value output

PWM cycle time	1 ... 15 ... 255 min
This parameter specifies the cycle time for the pulse width modulated command value (PWM).	
Visible only if the "Type of control" is set to the parameter "Switching PI control (PWM)".	

Polarity of the command values

Heating	normal (under current, this means opened) inverted (under current, this means closed)
---------	--

At this point, it is possible to specify whether the command value telegram for heating is output normally or in inverted form.

This parameter is only visible if the operating mode "Heating" or "Heating and cooling" is configured and not two-level operation.

Basic level heating	normal (under current, this means opened) inverted (under current, this means closed)
---------------------	--

At this point, it is possible to specify whether the command value telegram for the basic level heating is output normally or in inverted form.

This parameter is only visible if the operating mode "Heating" or "Heating and cooling" is configured along with two-level operation.

Additional level heating	normal (under current, this means opened) inverted (under current, this means closed)
--------------------------	--

At this point, it is possible to specify whether the command value telegram for the additional level heating is output normally or in inverted form.

This parameter is only visible if the operating mode "Heating" or "Heating and cooling" is configured along with two-level operation.

Cooling	normal (under current, this means opened) inverted (under current, this means closed)
---------	--

At this point, it is possible to specify whether the command value telegram for cooling is output normally or in inverted form.

This parameter is only visible if the operating mode "Cooling" or "Heating and cooling" is configured and not two-level operation.

Basic level cooling	normal (under current, this means opened) inverted (under current, this means closed)
<p>At this point, it is possible to specify whether the command value telegram for the basic level cooling is output normally or in inverted form. This parameter is only visible if the operating mode "Cooling" or "Heating and cooling" is configured along with two-level operation.</p>	

Additional level cooling	normal (under current, this means opened) inverted (under current, this means closed)
<p>At this point, it is possible to specify whether the command value telegram for the additional level cooling is output normally or in inverted form. This parameter is only visible if the operating mode "Cooling" or "Heating and cooling" is configured along with two-level operation.</p>	

Transmission behaviour

On change by (0 = inactive)	0... 3 ...100 %
<p>This parameter determines the size of the command value change that will automatically transmit continuous command value telegrams via the command value objects. Thus this parameter only affects command values which are configured to "Continuous PI control" and to the 1-byte additional command value objects of the "Switching PI control (PWM)".</p>	

Cyclical	0... 10 ...255 min
<p>This parameter determines the time interval for the cyclical transmission of the command values via all command value objects.</p>	

11.1.3.2 Command value limit parameters

FanCoil with controller -> Heating control -> General -> Control value limitation

Activation	Via object permanently active
<p>The command value limit allows the restriction of calculated command values to the range limits "minimum" and "maximum". The limits are permanently set in the ETS and, if command value limitation is active, can be neither undershot or exceeded during device operation.</p> <p>The "Activation" parameter defines the type of action of the limiting function. The command value limit can either be activated or deactivated using the 1-bit communication object "Command value limit - Activate / Deactivate" or be permanently active.</p>	

Active after reset	Active Inactive
<p>When controlling via the object, it is possible to have the controller activate the command value limit automatically after the bus voltage returns or after an ETS programming operation. This parameter defines the initialisation behaviour here.</p> <p>In the "inactive" setting, the command value limit is not automatically activated after a device reset. A "1" telegram must first be received via the "Command value limit - Activate/Deactivate" object for the limit to be activated.</p> <p>In the "active" setting, the controller activates the command value limit automatically after a device reset. To deactivate the limit a "0" telegram must be received via the "Command value limit - Activate / Deactivate" object. The limit can be switched on or off at any time using the object.</p> <p>This parameter is only visible if the command value limit can be activated via object.</p>	

Heating (also for basic level or additional level)

Minimum command value	5%, 10%, 15%, 20%, 25%, 30%, 35%, 40%, 45%, 50%
<p>The "Minimum command value" parameter specifies the lower command value limiting value for heating. With an active command value limit, the set minimum command value is not undershot by command values. If the controller calculates smaller command values, it sets the configured minimum command value. The controller transmits a 0% command value if no more heating or cooling energy has to be demanded.</p>	
Maximum command value	55%, 60%, 65%, 70%, 75%, 80%, 85%, 90%, 95% , 100%
<p>The "Maximum command value" parameter specifies the upper command value limiting value for heating. With an active command value limit, the set maximum command value is not exceeded. If the controller calculates larger command values, it sets the configured maximum command value.</p>	

Cooling (also for basic level or additional level)

Minimum command value	5%, 10%, 15%, 20%, 25%, 30%, 35%, 40%, 45%, 50%
<p>The "Minimum command value" parameter specifies the lower command value limiting value for cooling. With an active command value limit, the set minimum command value is not undershot by command values. If the controller calculates smaller command values, it sets the configured minimum command value. The controller transmits a 0% command value if no more heating or cooling energy has to be demanded.</p>	
Maximum command value	55%, 60%, 65%, 70%, 75%, 80%, 85%, 90%, 95% , 100%
<p>The "Maximum command value" parameter specifies the upper command value limiting value for cooling. With an active command value limit, the set maximum command value is not exceeded. If the controller calculates larger command values, it sets the configured maximum command value.</p>	

11.1.3.3 Command value output objects

Object for heating command value output and combined valve heating/cooling

Function: Command value

Function	Name	Type	DPT	Flag
Command value - Heating	RTR ... - Output	1-byte	5,001	C, R, -, T, A
Basic heating level command value	RTR ... - Output	1-byte	5,001	C, R, -, T, A
<p>1-byte object to output the continuous command value of the heating mode. In two-level heating mode, command value output for the basic heating. This object is only available in this way if the type of feedback control is configured to "Continuous PI control".</p> <p>* These objects are only visible if, with combined heating/cooling command value, separate command value objects are also displayed.</p>				

Function: Command value

Function	Name	Type	DPT	Flag
Command value - Heating	RTR ... - Output	1-bit	1,001	C, R, -, T, A
Basic heating level command value	RTR ... - Output	1-bit	1,001	C, R, -, T, A
<p>1-bit object to output the PWM command value of the heating mode. In two-level heating mode, command value output for the basic heating. This object is only available in this way if the type of feedback control is configured to "Switching PI control (PWM)".</p> <p>* These objects are only visible if, with combined heating/cooling command value, separate command value objects are also displayed.</p>				

Function	Name	Type	DPT	Flag
Command value - Heating - Status	RTR ... - Output	1-byte	5,001	C, R, -, T, A
Basic level heating command value - Status	RTR ... - Output	1-byte	5,001	C, R, -, T, A
<p>1-byte object for additional continuous output for the PWM command value of the heating mode. In two-level heating mode, command value output for the basic heating. This object is only available in this way if the type of feedback control is configured to "Switching PI control (PWM)".</p> <p>* These objects are only visible if, with combined heating/cooling command value, separate command value objects are also displayed.</p>				

Function: Command value

Function	Name	Type	DPT	Flag
Command value - Heating	RTR ... - Output	1-bit	1,001	C, R, -, T, A
Command value - Basic heating level	RTR ... - Output	1-bit	1,001	C, R, -, T, A

1-bit object to output the switching command value of the heating mode. In two-level heating mode, command value output for the basic heating. This object is only available in this way if the type of feedback control is configured to "Switching 2-point feedback control".

* These objects are only visible if, with combined heating/cooling command value, separate command value objects are also displayed.

Function: Command value

Function	Name	Type	DPT	Flag
Command value - Heating/Cooling / Command value basic level heating/cooling	RTR ... - Output	1-byte	5,001	C, R, -, T, A

1-byte object to output the combined continuous command value of the heating and cooling mode. In two-level heating/cooling mode, command value output for the basic level. This object is only available in this way if the command values for heating and cooling mode are output to a shared object (parameter-dependent). The type of feedback control must also be configured to "Continuous PI control".

Function: Command value

Function	Name	Type	DPT	Flag
Command value - Heating/Cooling / Command value basic level heating/cooling	RTR ... - Output	1-bit	1,001	C, R, -, T, A

1-bit object to output the combined PWM command value of the heating and cooling mode. In two-level heating/cooling mode, command value output for the basic level. This object is only available in this way if the command values for heating and cooling mode are output to a shared object (parameter-dependent). The type of feedback control must also be configured to "Switching PI control (PWM)".

Function	Name	Type	DPT	Flag
Command value - Heating/Cooling - Status / Command value basic level heating/cooling - Status	RTR ... - Output	1-byte	5,001	C, R, -, T, A

1-bit object for additional continuous output of the PWM command value of heating and cooling mode. In two-level heating and cooling mode, command value output for basic heating / basic cooling. This object is only available in this way if the type of feedback control is configured to "Switching PI control (PWM)".

Function: Command value

Function	Name	Type	DPT	Flag
Command value - Heating/Cooling / Command value basic level heating/cooling	RTR ... - Output	1-bit	1,001	C, R, -, T, A
1-bit object to output the combined switching command value of the heating and cooling mode. In two-level heating/cooling mode, command value output for the basic level. This object is only available in this way if the command values for heating and cooling mode are output to a shared object (parameter-dependent). The type of feedback control must also be configured to "Switching 2-point feedback control".				

Object for command value output, additional heating and combined valve additional heating/cooling

Function: Command value

Function	Name	Type	DPT	Flag
Command value - Additional level heating	RTR ... - Output	1-byte	5,001	C, R, -, T, A
1-byte object to output the continuous command value for additional heating in two-level operation. This object is only available in this way if the type of feedback control is configured to "Continuous PI control".				
* This object is visible only if, with combined heating/cooling command value, separate command value objects are also displayed.				

Function: Command value

Function	Name	Type	DPT	Flag
Command value - Additional level heating	RTR ... - Output	1-bit	1,001	C, R, -, T, A
1-bit object to output the continuous PWM command value for additional heating in two-level operation. This object is only available in this way if the type of feedback control is configured to "Switching PI control (PWM)".				
* This object is visible only if, with combined heating/cooling command value, separate command value objects are also displayed.				

Function	Name	Type	DPT	Flag
Command value - Additional level heating - Status	RTR ... - Output	1-byte	5,001	C, R, -, T, A
1-bit object for additional continuous output for the PWM command value for additional heating in two-level operation. This object is only available in this way if the type of feedback control is configured to "Switching PI control (PWM)".				
* This object is visible only if, with combined heating/cooling command value, separate command value objects are also displayed.				

Function: Command value

Function	Name	Type	DPT	Flag
Command value - Additional level heating	RTR ... - Output	1-bit	1,001	C, R, -, T, A
Command value - Additional level heating	RTR ... - Output	1-bit	1,001	C, R, -, T, A

1-bit object to output the switching command value for additional heating in two-level operation. This object is only available in this way if the type of feedback control is configured to "Switching 2-point feedback control".

Function: Command value

Function	Name	Type	DPT	Flag
Command value - Additional level heating/cooling	RTR ... - Output	1-byte	5,001	C, R, -, T, A

1-byte object to output the combined continuous command value for additional level in two-level operation. This object is only available in this way if the command values for heating and cooling mode are output to a shared object (parameter-dependent). The type of feedback control must also be configured to "Continuous PI control".

Function: Command value

Function	Name	Type	DPT	Flag
Command value - Additional level heating/cooling	RTR ... - Output	1-bit	1,001	C, R, -, T, A

1-bit object to output the combined switching PWM command value for additional level in two-level operation. This object is only available in this way if the command values for heating and cooling mode are output to a shared object (parameter-dependent). The type of feedback control must also be configured to "Switching PI control (PWM)".

Function	Name	Type	DPT	Flag
Command value - Additional level heating/cooling - Status	RTR ... - Output	1-byte	5,001	C, R, -, T, A

1-bit object for additional continuous output of the combined command value for additional level in two-level operation. This object is only available in this way if the command values for heating and cooling mode are output to a shared object (parameter-dependent). The type of feedback control must also be configured to "Switching PI control (PWM)".

Function: Command value

Function	Name	Type	DPT	Flag
Command value - Additional level heating/cooling	RTR ... - Output	1-bit	1,001	C, R, -, T, A
<p>1-bit object to output the combined switching command value for additional level in two-level operation. This object is only available in this way if the command values for heating and cooling mode are output to a shared object (parameter-dependent). The type of feedback control must also be configured to "Switching 2-point feedback control".</p>				

Object for command value output, cooling

Function: Command value

Function	Name	Type	DPT	Flag
Command value - Cooling	RTR ... - Output	1-byte	5,001	C, R, -, T, A
Command value - Basic level cooling	RTR ... - Output	1-byte	5,001	C, R, -, T, A
<p>1-byte object to output the continuous command value of the cooling mode. In two-level cooling mode, command value output for the basic cooling. This object is only available in this way if the type of feedback control is configured to "Continuous PI control".</p> <p>* These objects are only visible if, with combined heating/cooling command value, separate command value objects are also displayed.</p>				

Function: Command value

Function	Name	Type	DPT	Flag
Command value - Cooling	RTR ... - Output	1-bit	1,001	C, R, -, T, A
Command value - Basic level cooling	RTR ... - Output	1-bit	1,001	C, R, -, T, A
<p>1-bit object to output the PWM command value of the cooling mode. In two-level cooling mode, command value output for the basic cooling. This object is only available in this way if the type of feedback control is configured to "Switching PI control (PWM)".</p> <p>* These objects are only visible if, with combined heating/cooling command value, separate command value objects are also displayed.</p>				

Function	Name	Type	DPT	Flag
Command value - Cooling - Status	RTR ... - Output	1-byte	5,001	C, R, -, T, A
Command value - Basic level cooling - Status	RTR ... - Output	1-byte	5,001	C, R, -, T, A

1-bit object for additional continuous output of the PWM command value of the cooling mode. In two-level cooling mode, command value output for the basic cooling. This object is only available in this way if the type of feedback control is configured to "Switching PI control (PWM)".

* These objects are only visible if, with combined heating/cooling command value, separate command value objects are also displayed.

Function: Command value

Function	Name	Type	DPT	Flag
Command value - Cooling	RTR ... - Output	1-bit	1,001	C, R, -, T, A
Command value - Basic level cooling	RTR ... - Output	1-bit	1,001	C, R, -, T, A

1-bit object to output the switching command value of the cooling mode. In two-level cooling mode, command value output for the basic cooling. This object is only available in this way if the type of feedback control is configured to "Switching 2-point feedback control".

* These objects are only visible if, with combined heating/cooling command value, separate command value objects are also displayed.

Object for command value output, additional cooling

Function: Command value

Function	Name	Type	DPT	Flag
Command value - Additional level cooling	RTR ... - Output	1-byte	5,001	C, R, -, T, A

1-byte object to output the continuous command value for additional cooling in two-level operation. This object is only available in this way if the type of feedback control is configured to "Continuous PI control".

* This object is visible only if, with combined heating/cooling command value, separate command value objects are also displayed.

Function: Command value

Function	Name	Type	DPT	Flag
Command value - Additional level cooling	RTR ... - Output	1-bit	1,001	C, R, -, T, A
Command value - Additional level cooling	RTR ... - Output	1-bit	1,001	C, R, -, T, A

1-bit object to output the continuous PWM command value for additional cooling in two-level operation. This object is only available in this way if the type of feedback control is configured to "Switching PI control (PWM)".

* These objects are only visible if, with combined heating/cooling command value, separate command value objects are also displayed.

Function	Name	Type	DPT	Flag
Command value - Additional level cooling - Status	RTR ... - Output	1-byte	5,001	C, R, -, T, A

1-byte object for additional continuous output of the PWM command value for additional cooling in two-level operation. This object is only available in this way if the type of feedback control is configured to "Switching PI control (PWM)".

* These objects are only visible if, with combined heating/cooling command value, separate command value objects are also displayed.

Function: Command value

Function	Name	Type	DPT	Flag
Command value - Additional level cooling	RTR ... - Output	1-bit	1,001	C, R, -, T, A

1-bit object to output the switching command value for additional cooling in two-level operation. This object is only available in this way if the type of feedback control is configured to "Switching 2-point feedback control".

* These objects are only visible if, with combined heating/cooling command value, separate command value objects are also displayed.

11.1.3.4 Objects for command value limit

Function	Name	Type	DPT	Flag
Command value limit - Activate/Deactivate	RTR ... - Input	1-bit	1,001	C, -, W, -, U

1-bit object for activating or deactivating the command value limit.

11.1.4 Controller status

Heating/cooling message

Depending on the set operating mode, separate objects can be used to indicate whether the controller is currently demanding heating or cooling energy and is thus actively heating or cooling. As long as the heating command value is > "0", a "1" tele-

gram will be transmitted via the object "Heating status object". The signal telegram is only reset when the command value is "0" ("0" telegram is transmitted). The same applies to the object "Cooling status object".

The signal objects can be enabled by the "Heating status object" or "Cooling status object" parameters in the parameter branch "FanCoil with controller -> Heating control -> General -> Status". The control algorithm controls the signal objects. Please note that the command values are recalculated every 30 s, thus updating the signal objects.

The control algorithm also controls the display symbols for heating and cooling in parallel with the signalling objects. For the "Heating" or "Cooling" duration, the display shows the corresponding symbol in the bottom right-hand display arealcons in the display.



Heating/cooling

Controller status

The room temperature controller can transmit its current status to the KNX. A choice of data formats is available for this. The "Status" parameter enables the Status parameter page. The different status objects can be activated there individually.

- The KNX-compliant controller status feedback is harmonised on a manufacturer-independent basis.
- The objects "Controller status RHCC - KNX compliant", "Controller status RTC - KNX compliant" and "Controller status RTSM - KNX compliant" display elementary basic functions of the controller.
- These objects are supplemented by the two 1-byte objects "Operating mode status" and "Forced operating mode status" (DPT 20.102), which report back the operating mode actually set at the controller. The last two objects mentioned above are generally used to enable controller extensions to display the controller operating mode correctly in the KNX compliant status display. Therefore, these objects should be connected with controller extensions if the KNX-compliant status feedback is not configured.

Bit coding of the 2-byte object "Controller status RHCC - KNX compliant" (DPT 22.101)

Bit of the status telegram	Meaning on "1"	Meaning on "0"
0	Error	no error
1	not used (permanent "0")	
2	not used (permanent "0")	
3	not used (permanent "0")	
4	not used (permanent "0")	
5	not used (permanent "0")	
6	not used (permanent "0")	

Bit of the status telegram	Meaning on "1"	Meaning on "0"
7	not used (permanent "0")	
8	"Heating" operating mode	"Cooling" operating mode
9	not used (permanent "0")	
10	not used (permanent "0")	
11	not used (permanent "0")	
12	Controller disabled (dew point operation)	Controller enabled
13	Frost alarm (frost protection temperature undershot)	no frost alarm (frost protection temperature exceeded)
14	Heat alarm (heat protection temperature exceeded)	no heat alarm (heat protection temperature undershot)
15	not used (permanent "0")	

Bit coding of the 2-byte object "Controller status RTC - KNX compliant" (DPT 22.103)

Bit of the status telegram	Meaning on "1"	Meaning on "0"
0	Error	no error
1	"Heating" operating mode	"Cooling" operating mode
2	Controller disabled (dew point operation)	Controller enabled
3	Frost alarm (frost protection temperature undershot)	no frost alarm (frost protection temperature exceeded)
4	Heat alarm (heat protection temperature exceeded)	no heat alarm (heat protection temperature undershot)
5	Controller inactive (deadband)	Controller active
6	not used (permanent "0")	
7	"Heating" operating mode enabled	"Heating" operating mode disabled
8	"Cooling" operating mode enabled	"Cooling" operating mode disabled
9	not used (permanent "0")	
10	not used (permanent "0")	
11	not used (permanent "0")	
12	not used (permanent "0")	
13	not used (permanent "0")	
14	not used (permanent "0")	
15	not used (permanent "0")	

Bit coding of the 1-byte object "Controller status RTSM - KNX compliant" (DPT 21.107)

Bit of the status telegram	Meaning on "1"	Meaning on "0"
0	<p>Window opened</p> <p>(For "Frost/heat protection = automatic frost protection":</p> <ul style="list-style-type: none"> – The bit is active if the automatic frost protection of the temperature drop detection is active. <p>For "Frost/heat protection = via window status":</p> <ul style="list-style-type: none"> – The bit is active if at least one window is open after the delay time has elapsed.) 	<p>no window open</p> <p>(For "Frost/heat protection = automatic frost protection":</p> <ul style="list-style-type: none"> – The bit is inactive if the automatic frost protection of the temperature drop detection is inactive. <p>For "Frost/heat protection = via window status":</p> <ul style="list-style-type: none"> – The bit is inactive if all windows are closed.)
1	Presence (Presence detector)	no presence (presence detector)
2	Presence (Presence button)	no presence (presence button)
3	Comfort extension active	Comfort extension inactive
4	Forced operating mode active	Forced operating mode inactive
5	not used (permanent "0")	
6	not used (permanent "0")	
7	not used (permanent "0")	

- i** Bit 0 of the 1-byte object "Controller status RTSM - KNX compliant" (DPT 21.107) becomes active, depending on the setting of the parameter "Frost/heat protection".

11.1.4.1 Status output parameters

FanCoil with controller -> Heating control -> General -> Status

Heating / Cooling (depending on the operating mode of the controller)

Status object - Heating	Active Inactive
Depending on the set operating mode, a separate object can be used to signal whether the controller is currently demanding heating energy and is thus actively heating. The "Yes" setting here enables the message function for heating.	

Status object - Cooling	Active Inactive
Depending on the set operating mode, a separate object can be used to signal whether the controller is currently demanding cooling energy and is thus actively cooling. The "Yes" setting here enables the message function for cooling.	

Controller status

Status objects - Operating mode	Active Inactive
The room temperature controller can transmit its current status to the KNX. If the parameter is activated, the objects "Operating mode - Preset - Status", "Operating mode - Active mode - Status" and "Operating mode - Forced - Status" are visible.	

Status object – RHCC	Active Inactive
The room temperature controller can transmit its current status to the KNX. If the parameter is activated, the object "Controller status RHCC" is visible.	

Status object – RTC	Active Inactive
The room temperature controller can transmit its current status to the KNX. If the parameter is activated, the object "Controller status RTC" is visible.	

Status object – RTSM	Active Inactive
The room temperature controller can transmit its current status to the KNX. If the parameter is activated, the object "Controller status RTSM" is visible.	

11.1.4.2 Objects for controller status

Function	Name	Type	DPT	Flag
Operating mode - Pre-set	RTR ... - Input	1-byte	20,102	C, -, W, T, U
<p>1-byte object for change-over of the operating mode of the controller according to the KNX specification.</p> <p>After the mains voltage returns or an ETS programming operation, the current operating mode is transmitted by means of this object.</p>				
Function	Name	Type	DPT	Flag
Operating mode - Pre-set - Status	RTR ... - Output	1-byte	20,102	C, R, -, T, A
<p>1-byte object used by the controller to output the current operating mode. This object is generally used to enable controller extensions to display the controller operating mode correctly in the KNX compliant status display. Therefore this object should be connected with controller extensions if the KNX compliant status feedback is not configured.</p> <p>After the mains voltage returns or an ETS programming operation, the current status is transmitted by means of this object. This object is only available if the parameter "Status objects - Operating mode" is activated.</p>				
Function	Name	Type	DPT	Flag
Operating mode - Forced	RTR ... - Input	1-byte	20,102	C, W, -, T, U
<p>1-byte object for forced change-over (highest priority) of the operating mode of the controller according to the KNX specification.</p>				
Function	Name	Type	DPT	Flag
Operating mode - Forced - Status	RTR ... - Output	1-byte	20,102	C, R, -, T, A
<p>1-byte object used by the controller to output the operating mode in the event of restraint. This object is generally used to enable controller extensions to display the controller operating mode correctly in the KNX compliant status display. Therefore this object should be connected with controller extensions if the KNX compliant status feedback is not configured.</p> <p>After the mains voltage returns or an ETS programming operation, the current status is transmitted by means of this object. This object is only available if the parameter "Status objects - Operating mode" is activated.</p>				

Function	Name	Type	DPT	Flag
Controller status RHCC - KNX-compliant	RTR ... - Output	2-byte	22,101	C, R, -, T, A
2-byte object that the controller uses to display elementary basic functions in a KNX-harmonised manner (RHCC).				
After the mains voltage returns or an ETS programming operation, the current status is transmitted by means of this object.				

Function	Name	Type	DPT	Flag
Controller status RTSM - KNX-compliant	RTR ... - Output	1-byte	21,107	C, R, -, T, A
2-byte object that the controller uses to display elementary basic functions in a KNX-harmonised manner (RTSM).				
After the mains voltage returns or an ETS programming operation, the current status is transmitted by means of this object.				

Function	Name	Type	DPT	Flag
Controller status RTC - KNX-compliant	RTR ... - Output	2-byte	22,103	C, R, -, T, A
2-byte object that the controller uses to display elementary basic functions in a KNX-harmonised manner (RTC).				
After the mains voltage returns or an ETS programming operation, the current status is transmitted by means of this object.				

Function	Name	Type	DPT	Flag
Heating - Status	RTR ... - Output	1-bit	1,001	C, R, -, T, A
1-bit object for the controller to report a request for heating energy. Object value = "1": energy request, object value = "0": no energy request.				

Function	Name	Type	DPT	Flag
Cooling - Status	RTR ... - Output	1-bit	1,001	C, R, -, T, A
1-bit object for the controller to report a request for cooling energy. Object value = "1": energy request, object value = "0": no energy request.				

11.1.5 Boost function

The boost function can be used temporarily to heat or cool a room intensively. If the boost function is activated via the "Boost - Activate / Deactivate" object, the command value is set to maximum (ON or 100%) in the standard parameterisation for a duration of 5 minutes. After the time has elapsed, the boost switches off again automatically.

Once the boost function has elapsed, the controller checks the current actual temperature and the setpoint temperature. The command values set to maximum by the boost function are not switched off until the corresponding temperature limits are exceeded in heating mode and undershot in cooling mode.

The "Boost function" parameter in the parameter node "FanCoil controller -> Heating control -> General -> Enabled functions" enables the "Boost function" parameter page. The remaining parameters can be set there.

The current status of the boost function and the residual time of a current boost can be sent to the bus.

While the boost function is switched on, the display shows a rocket symbol in the top left-hand display arealcons in the display.



The boost function is active

- i** The boost function cannot be retriggered.
- i** The boost function can be aborted at any time.
- i** The controller calculates the command values cyclically every 30 seconds. This can delay the adoption of the command value by a maximum of 30 s. As this delay affects switching on and off, the duration of the boost function remains unchanged.

11.1.5.1 Boost function parameters

FanCoil with controller -> Heating control -> General -> Boost function

Effect on	Heating Cooling Heating and cooling
The boost function can optionally be used for heating only, for cooling only or for both heating and cooling. The options available for this parameter depend on the operating mode set on the parameter page "FanCoil with controller".	
In heating mode, effect on	Basic level heating Additional level heating Basic and additional level heating
In the case of heating with the basic and additional levels, the boost function can optionally have an effect on the basic level only, the additional level only or both the basic and additional levels.	
In cooling mode, effect on	Basic level cooling Additional level cooling Basic and additional level cooling
In the case of cooling with the basic and additional levels, the boost function can optionally have an effect on the basic level only, the additional level only or both the basic and additional levels.	

Heating

Boost period	1 ... 5 ... 60 min
The device performs the boost according to the configuration of this parameter for a period of 1 to 60 minutes.	

Boost - Command value	0 ... 100 %
For the configured duration, the command value is set to the value parameterised here, e. g. maximum (ON or 100%).	

Cooling

Boost period	1 ... 5 ... 60 min
The device performs the boost according to the configuration of this parameter for a period of 1 to 60 minutes.	

Boost - Command value	0 ... 100 %
For the configured duration, the command value is set to the value parameterised here, e. g. maximum (ON or 100%).	

Transmission behaviour

Cyclical transmission of residual time (0 = inactive)	0...59 min 0 ... 10...59 s
If the boost function is activated, the object "Boost - Remaining run time" can cyclically transmit the residual time of the running boost function in seconds.	

11.1.5.2 Objects for boost function

Function	Name	Type	DPT	Flag
Boost - Activate/Deactivate	RTR ... - Input	1-bit	1,010	C, -, W, -, U
1-bit input object for requirement-orientated activation and deactivation of the boost function. The telegram polarity is fixed: "0" = boost inactive, "1" = boost active. Updates of the object from "1" to "1" or "0" to "0" do not produce a reaction.				

Function	Name	Type	DPT	Flag
Boost - Status	RTR ... - Output	1-bit	1,011	C, R, -, T, -
1-bit object via which the controller outputs the current status of the boost function. When the boost function is activated, the status object is set to the value "1". When the boost function is deactivated, the status object is set to the value "0". After a reset, the status message object value is "0". The status object is only sent when there is a change.				

Function	Name	Type	DPT	Flag
Boost - Remaining run time	RTR ... - Output	2-byte	7,005	C, R, -, T, -
2-byte object via which the controller outputs the period of the boost function. The residual time of the boost function is transmitted via the object in 10 second increments.				

11.1.6 Floor temperature monitoring

The cyclical monitoring of the floor temperature can be activated in the controller in order to influence the minimum or maximum temperature of a floor heating system. If the monitoring is enabled in the ETS, the controller continuously monitors the floor temperature. If the floor temperature exceeds a specified limiting value during heating or falls below a specified limiting value during cooling, the controller switches off the corresponding command value for heating or cooling. This switches off the heating or cooling and the system cools down or heats up. The controller will only set the most recently calculated command value again when the temperature exceeds / falls below the limiting value minus a hysteresis of 1 K.

- i** With a pulse width-modulated command value, the temperature limit only switches off the command value when the current PWM time cycle has elapsed.
- i** Depending on the configuration, the temperature may have a strong impact on the controller behaviour. Poor parameterisation of the limit temperature (limit temperature near to the room/setpoint temperature) means that it is possible that the specified setpoint temperature for the room can never be reached!
- i** The cyclical monitoring of the floor temperature is used to increase the comfort behaviour of the heating/cooling system and must not be used as a safety-relevant protection function (immediate forced switch-off of the heating/cooling performance).

Which operation the cyclical monitoring should be applied to can be set in the ETS. It is possible to limit the minimum and / or the maximum floor temperature by the parameter "Monitoring of". In two-level heating or cooling mode, it is also possible to set whether the floor temperature limit applies to the basic level only, the additional level only or both the basic and additional levels.

The underfloor heating temperature to be monitored is fed into the controller via the KNX communication object "Floor temperature - Measured value". This object can be used to inform the controller of the current floor temperature using suitable temperature value telegrams from other bus devices (e. g. analogue input with temperature sensor, etc.).

The minimum and maximum limit temperatures the underfloor heating system is permitted to reach are specified in the ETS via the parameters "Maximum permissible floor temperature" and "Minimum permissible floor temperature". The temperatures can be set to a value between 10 ... 45 °C. If the limit temperature is exceeded in heating mode or fallen below in cooling mode, the controller switches the floor heat-

ing system off via the command value. As soon as the floor temperature has fallen 1 K below the limit temperature in heating mode or risen 1 K above the limit temperature in cooling mode, the controller switches the command value on again, assuming this is provided for in the control algorithm. The hysteresis 1 K is fixed.

- i** The cyclical monitoring does not affect the "Heating" or "Cooling" message telegrams. If the floor temperature exceeds or falls below the limiting value, only the command value is switched off. In this case, the "Heating" or "Cooling" message remains active.
- i** The limiting temperatures for minimum and maximum are not checked for plausibility. The following generally applies: "Minimum permissible floor temperature" < allowed floor temperature range < "Maximum permissible floor temperature".

11.1.6.1 Floor temperature monitoring parameters

FanCoil with controller -> Heating control -> General -> Floor temperature monitoring

Monitoring of	Maximum floor temperature Minimum floor temperature Maximum and minimum floor temperature
This parameter determines which operating mode the cyclical floor temperature monitoring should be applied to. Either heating (maximum floor temperature), cooling (minimum floor temperature) or heating and cooling can be limited.	
Effect on	Basic level Additional level Basic and additional level
Depending on which heating or cooling circuit is used for the floor, this parameter defines which level is affected by the floor temperature monitoring.	

Heating

Maximum permissible floor temperature	10 ... 35 ... 45 °C
The maximum limit temperature which the floor may reach in heating mode is specified here. If this temperature is exceeded, the controller switches the underfloor heating system off using the command value. As soon as the floor temperature has fallen 1 K under the limit temperature, the controller switches the command value on again, assuming that this is provided for in the control algorithm.	

Cooling

Minimum permissible floor temperature	10 ... 45 °C
The minimum limit temperature which the floor may reach in cooling mode is specified here. If the temperature falls below this value, the controller switches the underfloor cooling system off using the command value. As soon as the floor temperature has risen 1 K above the limit temperature, the controller switches the command value on again, assuming that this is provided for in the control algorithm.	

11.1.6.2 Objects for floor temperature monitoring

Function	Name	Type	DPT	Flag
Floor temperature - Limiting value exceeded/undershot - Status	RTR ... - Output	1-bit	1,011	C, R, -, T, A
<p>1-bit object for the status output of the monitoring of the configured limiting values of the floor temperature. If the monitoring is enabled in the ETS, the controller continuously monitors the floor temperature. If the floor temperature exceeds a specified limiting value during heating or falls below a specified limiting value during cooling, the controller switches off the corresponding command value for heating or cooling. This switches off the heating or cooling. The controller will only set the most recently calculated command value again when the temperature exceeds / falls below the limiting value minus a hysteresis of 1 K again.</p>				
Function	Name	Type	DPT	Flag
Floor temperature - Measured value	RTR ... - Input	2-byte	9,001	C, -, W, -, U
<p>2-byte object for coupling an external temperature sensor for floor temperature monitoring.</p> <p>The temperature value must always be specified in the format "°C".</p>				

11.1.7 Setpoint temperature limit, cooling

In accordance with statutory requirements in Germany and elsewhere, the temperature at the workplace should be a maximum of 26 °C, or at least 6 K below outdoor temperatures higher than 32 °C. Exceeding these limits is only permissible in exception circumstances. To meet these requirements, the room temperature controller offers a setpoint temperature limit, which is only effective in cooling mode. If necessary, the controller limits the setpoint temperature to specific values and prevents an adjustment beyond the limits.

The "Limitation type" parameter in the parameter node "FanCoil with controller -> Heating control -> General -> Setpoint temperature limit, cooling" can activate the limit and specify its function. The following settings are possible:

- Setting "Only difference to outdoor temperature"

In this setting, the outdoor temperature is monitored and compared to the active setpoint temperature. The desired maximum temperature difference to the outdoor temperature can be specified in the range between 1 K and 15 K. The specification is made using the parameter "Difference between setpoint temperature and outdoor temperature of". The value can be set in step widths of 1 K.

If the outdoor temperature rises above the value of the parameter "Limit above outdoor temperature of", then the controller activates the setpoint temperature limit. It then permanently monitors the outdoor temperature and raises the setpoint temperature so that it is beneath the outdoor temperature by the amount configured. Should the outdoor temperature continue to rise, the controller raises the setpoint temperature until the required difference to the outdoor temperature is reached.

ure is achieved. It is then not possible to undershoot the raised setpoint, e. g. by changing the basic setpoint change.

The change to the setpoint temperature limit is temporary. It only applies for as long as the outdoor temperature exceeds the value of the parameter "Limit above outdoor temperature of".

With the setpoint temperature limit, the configured temperature difference relates to the setpoint temperature of the Comfort mode for cooling. In other operating modes, the temperature distance to Comfort mode must be taken into account.

Example:

In the ETS, the difference between the setpoint temperature and the outdoor temperature is set to 6 K. The standby setpoint temperature is configured to 2 K higher than the comfort setpoint temperature. The result of this is that, for command value limiting, the setpoint temperature in Standby mode may only be a maximum of 4 K below the outdoor temperature. The setpoint temperature limit applies to Night mode in the same way.

- i** The automatic raising of the setpoint temperature by the setpoint temperature limit goes only as far as the configured heat protection temperature. Therefore the heat protection temperature can never be exceeded.
- i** A basic setpoint shift never affects an active setpoint temperature limit with differential measurement to the outdoor temperature! In this case, the setpoint temperature limit only works with the unshifted basic setpoint. A setpoint shift active before the limitation is restored after the limitation, if it was not reset in another way, e. g. by an operating mode switchover.
- i** If the setpoint temperature limit is active, the difference between the basic cooling and additional cooling levels is not taken into account. The command values for both levels are identical. Only when the temperature falls below the limit temperature is the difference between the levels considered again.
- Setting "only maximum setpoint temperature"
In this setting, no setpoint temperatures that are greater than the maximum setpoint temperature configured in the ETS are permitted in cooling mode for the Comfort, Standby and Night modes. The maximum setpoint temperature is specified in the parameter "Maximum setpoint temperature in cooling mode" and can be configured within the limits 20 °C to 35 °C in steps of 1 °C. With an active limit, no larger setpoint can be set in cooling operation, e. g. by a basic setpoint change or a setpoint shift. However, heat protection is not influenced by the setpoint temperature limit.
The maximum setpoint temperature configured in the ETS generally relates to the comfort setpoint temperature of cooling mode. In other operating modes, the temperature distance to Comfort mode must be taken into account. Example...
The maximum setpoint temperature is configured to 26 °C. The standby setpoint temperature is configured to 2 K higher than the comfort setpoint temper-

ature. The result of this is that, for command value limiting, the setpoint temperature in Standby mode is limited to 28 °C. The setpoint temperature limit applies to Night mode in the same way.

- Setting "Maximum setpoint temperature and difference to outdoor temperature"

This setting is a combination of the two above-mentioned settings. In the downward direction, the setpoint temperature is limited by the maximum outdoor temperature difference, whilst in the upward direction, the limit is made by the maximum setpoint.

The maximum setpoint temperature has priority over the outdoor temperature difference. This means that the controller keeps on raising the setpoint temperature according to the difference to the outdoor temperature configured in the ETS until the maximum setpoint temperature or the heat protection temperature is exceeded. Then the setpoint is limited to the maximum value.

A setpoint limit enabled in the ETS can be activated or deactivated as necessary using a 1-bit object. For this, the parameter "Activation" can be set to "via object". In this case, the controller only takes the setpoint limit into account if it has been enabled via the object "Setpoint temperature limit - Activate / Deactivate" ("1" telegram). If the limitation is not enabled ("0" telegram), the cooling setpoint temperatures are not limited. After a device reset (bus voltage return, ETS programming operation), the object value is "0", meaning that the setpoint limit is inactive.

 The setpoint limit has no function in Heating mode.

Status message of the setpoint temperature limit

If a setpoint temperature limit is active, this is signalled to the bus via the object "Setpoint temperature limit - Status". This makes it possible for the user to recognise a changed temperature setpoint. After a reset, the status message object value is "0". This corresponds to the normal setpoint of the operating modes "Comfort", "Standby" and "Night". The setpoint temperature status is only sent when there is a change.

11.1.7.1 Setpoint temperature limit parameters

FanCoil with controller -> Heating control -> General -> Cooling setpoint temperature limit

Limitation type	only difference to outdoor temperature only maximum setpoint temperature Maximum setpoint temperature and difference to outdoor temperature
<p>The variable on which the setpoint temperature limit depends can be defined here.</p> <p>"Only difference to outdoor temperature": In this setting, the outdoor temperature is monitored and compared with the active setpoint temperature. The specification of the maximum temperature difference to the outdoor temperature is made using the "Difference to outdoor temperature in cooling mode" parameter. If the outdoor temperature rises above 32 °C, then the controller activates the setpoint temperature limit. It then permanently monitors the outdoor temperature and raises the setpoint temperature so that is beneath the outdoor temperature by the amount configured. Should the outdoor temperature continue rising, the controller raises the setpoint temperature until the required difference to the outdoor temperature is reached, or, at most, the heat protection temperature. It is then not possible to undershoot the raised setpoint, e. g. by changing the basic setpoint change. The change to the setpoint temperature limit is temporary. It only applies for as long as the outdoor temperature exceeds 32 °C.</p> <p>"Only maximum setpoint temperature": In this setting, no setpoint temperatures that are greater than the maximum setpoint configured in the ETS are permitted in cooling mode for the Comfort, Standby and Night modes. The maximum temperature setpoint is specified by the "Max. setpoint temperature in cooling operation" parameter. With an active limit, no larger setpoint can be set in cooling operation, e. g. by a basic setpoint change or a setpoint shift. However, heat protection is not influenced by the setpoint temperature limit.</p> <p>"Maximum setpoint temperature and difference to outdoor temperature": This setting is a combination of the two above-mentioned settings. In the downward direction, the setpoint temperature is limited by the maximum outdoor temperature difference, whilst in the upward direction, the limit is made by the maximum setpoint. The maximum setpoint temperature has priority over the outdoor temperature difference. This means that the controller keeps on raising the setpoint temperature according to the difference to the outdoor temperature configured in the ETS until the maximum setpoint temperature or the heat protection temperature is exceeded. Then the setpoint is limited to the maximum value.</p>	
Limit from an outdoor temperature of	20...32...45 °C
<p>This parameter defines the outdoor temperature at which limitation of the setpoint temperature becomes active in cooling mode.</p>	

Difference between setpoint temperature and outdoor temperature of	1 ...6 ...15 K
<p>This parameter defines the maximum difference between the setpoint temperature in Comfort mode and the outdoor temperature with an active setpoint temperature limit. This parameter is visible only if setpoint temperature monitoring is enabled. However, this is only if the parameter "Setpoint temperature limit in cooling operation" is then set to "Only difference to outdoor temperature" or "Max. setpoint temperature and difference to outdoor temperature".</p>	
Maximum setpoint temperature	+20 ... +26 ... +35 °C
<p>This parameter defines the maximum setpoint temperature in Comfort mode with an active setpoint temperature limit. This parameter is visible only if setpoint temperature monitoring is enabled. However, this is only if the parameter "Setpoint temperature limit in cooling operation" is then set to "Only max. setpoint temperature" or "Max. setpoint temperature and difference to outdoor temperature".</p>	
Activation	Via object permanently active
<p>A setpoint limit enabled in the ETS can be activated or deactivated as necessary using a 1-bit object. For this, this parameter can be set to "Yes". In this case, the controller only takes the setpoint limit into account, if it has been enabled via the object "Cooling setpoint temperature limit" ("1" telegram). If the limitation is not enabled ("0" telegram), the cooling setpoint temperatures are not limited. This parameter is visible only if setpoint temperature monitoring is enabled.</p>	

11.1.7.2 Objects for setpoint temperature limit

Function	Name	Type	DPT	Flag
Setpoint temperature limit - Activate / Deactivate	RTR ... - Input	1-bit	1,001	C, -, W, -, U
<p>1-bit object for activation or deactivation of a setpoint temperature limit.</p> <ul style="list-style-type: none"> - "0" = deactivate raising of setpoint - "1" = activate raising of setpoint <p>If the activation of the setpoint limit is set to "permanently active", the communication object will not be visible.</p>				
Function	Name	Type	DPT	Flag
Setpoint temperature limit - Status	RTR ... - Output	1-bit	1,011	C, R, -, T, A
<p>1-bit object for signalling an active setpoint temperature limit.</p> <ul style="list-style-type: none"> - "0" = raising of setpoint not active - "1" = raising of setpoint active 				

Function	Name	Type	DPT	Flag
Outdoor temperature - Measured value	RTR ... - Input	2-byte	9,001	C, -, W, -, U
<p>The measured value of the outdoor temperature is required if a direct dependency between the setpoint temperature and the outdoor temperature is to be established. When the "Cooling setpoint temperature limit" or "Heating setpoint temperature increase" functions are activated, such a connection exists and this object becomes visible.</p>				

11.1.8 Setpoint temperature increase, heating

The room temperature controller offers a setpoint temperature increase, which is only effective in heating mode.

The comfort and standby setpoints are raised gradually as the outdoor temperature falls. This counteracts the radiative cooling from outdoor walls in winter, increasing the sense of well-being. The working range can be configured and is defined via the parameter "Raise from difference between setpoint temperature and outdoor temperature of".

The following values are used for calculation of the setpoint temperature increase:

- Setpoint temperature (before increase)
- current outdoor temperature
- configured difference between setpoint temperature and outdoor temperature
- Increase factor

These values are used in the following formula:

Setpoint temperature increase = Setpoint temperature + (Setpoint temperature - (Outdoor temperature + Difference between setpoint temperature and outdoor temperature)) x Increase factor

Example for setpoint temperature increase:

- Heating Comfort mode setpoint temperature = Specified setpoint temperature = 21 °C

- Difference between setpoint temperature and outdoor temperature = 10 K

- Increase factor = 10

Outdoor temperature = 11 °C, Preset setpoint + (Preset setpoint (Outdoor temperature + Difference between setpoint temperature and outdoor temperature) x Factor) = 21.0 °C

-> Set setpoint temperature = Specified setpoint temperature = 21 °C

Outdoor temperature = 10 °C, Preset setpoint + (Preset setpoint (Outdoor temperature + Difference between setpoint temperature and outdoor temperature) x Factor) = 21.1 °C

-> Set setpoint temperature = Calculated setpoint temperature = 21.1 °C

Example for setpoint temperature increase:

- Heating Comfort mode setpoint temperature = Specified setpoint temperature = 21 °C
- Difference between setpoint temperature and outdoor temperature = 10 K
- Increase factor = 10

Outdoor temperature = 9 °C, Preset setpoint + (Preset setpoint (Outdoor temperature + Difference between setpoint temperature and outdoor temperature) x Factor) = 21.2 °C

-> Set setpoint temperature = Calculated setpoint temperature = 21.2 °C

Outdoor temperature = 8 °C, Preset setpoint + (Preset setpoint (Outdoor temperature + Difference between setpoint temperature and outdoor temperature) x Factor) = 21.3 °C

-> Set setpoint temperature = Calculated setpoint temperature = 21.3 °C

If the value of the shifted outdoor temperature (grey characteristic line) falls below the value of the specified setpoint temperature (green characteristic line), the calculated setpoint temperature (blue characteristic line) becomes active. When setpoint temperature increase is activated, the calculated setpoint is then set as the setpoint temperature. Correspondingly, the specified setpoint temperature is reactivated when the calculated setpoint temperature value falls below the specified setpoint temperature.

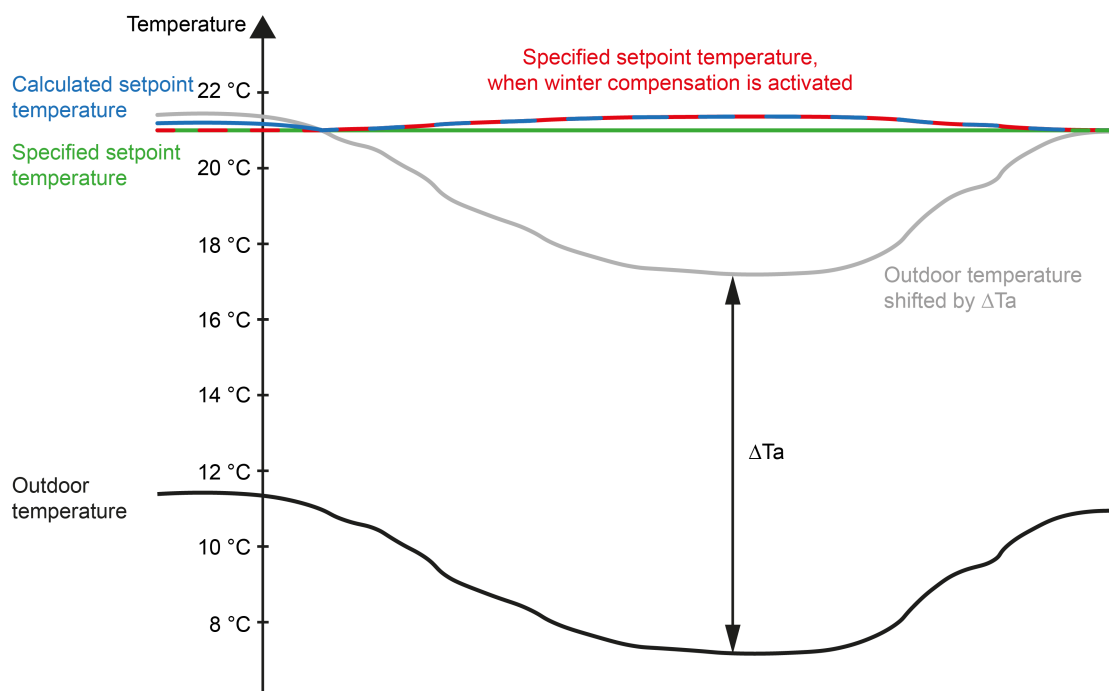

Figure 30: Example for winter compensation

ΔT_a configured difference between setpoint temperature and outdoor temperature

Additional information about setpoint temperature increase, heating

- The precondition for "setpoint temperature increase, heating" is reception of a valid outdoor temperature.

- Setpoints shifted by "setpoint temperature increase, heating" are checked against the frost and heat protection temperatures and if they fall below or exceed them respectively, they are restricted to these values.
- The "setpoint temperature increase, heating" only works in the operating modes Comfort and Standby.
- Switching between heating and cooling changes the operation; which is the corresponding precondition for "setpoint temperature increase, heating".
- "Cooling" operation switches "setpoint temperature increase, heating" to inactive and sets its offset to the value "0".
- An operating mode switchover to Comfort or Standby operating mode does not affect the "setpoint temperature increase, heating". By contrast, the Night and Frost/heat protection modes switch the "setpoint temperature increase, heating" to inactive.

Status message of setpoint temperature increase, heating

If "setpoint temperature increase, heating" is active, this is signalled to the bus via the object "Setpoint temperature increase - Status". This makes it possible for the user to recognise a changed temperature setpoint. After a reset, the status message object value is "0". This corresponds to the normal setpoint of the operating modes "Comfort", "Standby" and "Night". The setpoint temperature status is only sent when there is a change.

11.1.8.1 Setpoint temperature increase parameters

Increase beyond difference between setpoint temperature and outdoor temperature of	10 ...15 ...20 K
This parameter defines the difference between the setpoint temperature and the outdoor temperature beyond which the setpoint temperature increase gradually takes effect.	
Increase factor	0...0.2
This parameter defines the intensity of the setpoint temperature increase	

11.1.8.2 Objects for setpoint temperature increase

Function	Name	Type	DPT	Flag
Setpoint temperature increase - Status	RTR ... - Output	1-bit	1,011	C, R, -, T, A
1-bit object for signalling an active setpoint temperature increase.				
– "0" = raising of setpoint not active				
– "1" = raising of setpoint active				

11.1.9 Scenes

Up to 64 scenes can be created for the room temperature controller and scene values (operating mode) stored. The scene values are recalled or stored via a separate scene extension object. The data point type of the extension object allows all scenes to be addressed.

The scene function must be enabled so that the required communication objects and parameters become visible.

The scene configuration selected in the parameterization decides whether the number of scenes is either variable (1 ... 64) or alternatively fixed to the maximum (64).

- Scene configuration = "variable (1 ... 64 scenes)"
With this setting, the number of scenes used can be selected anywhere in the range 1 to 64. The parameter "Number of scenes" decides how many scenes are visible in the ETS and can therefore be used. It is possible to specify which scene number (1 ... 64) controls each scene.
- Scene configuration = "fixed (64 scenes)"
With this setting, all scenes are always visible and can therefore be used. The scenes are controlled via permanently assigned scene numbers (1 ... 64) (scene number 1 -> scene 1, scene number 2 -> scene 2 ...). If necessary, individual scenes can be deactivated.

The scene function can be combined together with other functions of the room temperature controller, whereby the last received or set state is always executed.

Presetting a scene recall delay

Each scene recall of the room temperature controller can also be optionally delayed. With this feature, dynamic scene sequences can be configured if several scene outputs are combined with cyclical scene telegrams.

Prerequisite

The scene function must be enabled.

- Activate the "Delay scene recall" parameter.

The delay time is now activated and can be configured separately. The delay only affects the scene recall of the room temperature controller. The delay time is started on arrival of a recall telegram. Only after the time has elapsed is the corresponding scene called up and the operating mode set.

- i** Each scene recall telegram restarts the delay time and retriggers it. If a new scene recall telegram is received while a delay is active (scene recall not yet executed), the old (and not yet recalled scene) will be rejected and only the scene last received executed.
- i** The scene recall delay has no influence on the storage of scene values. A scene storage telegram within a scene recall delay terminates the delay and thus the scene recall.

Setting the behaviour during ETS programming

When saving a scene, the operating modes are stored internally in the device in a non-volatile manner. To ensure that the stored values are not replaced by the originally programmed scene operating modes during an ETS programming operation of the application program or the parameters, the actuator can prevent the operating modes from being overwritten. As an alternative, the original values can be reloaded into the device during each programming run of the ETS.

Prerequisite

The scene function must be enabled on the "Fan coil with controller -> Heating control -> General -> Enabled" parameter card.

- Activate the "Overwrite values stored in the device during the ETS programming operation" parameter on the parameter page "FanCoil with controller -> Heating control -> General -> Scenes".

With each ETS programming operation of the application program or the parameters, the scene operating modes configured in the ETS are programmed into the actuator. This may overwrite the scene operating modes stored in the device by means of a storage function.

- Deactivate the parameter "Overwrite values stored in the device during the ETS programming operation".

Scene operating modes that may have been stored in the device by means of a storage function are maintained. If no scene switching states have been stored, the last operating modes programmed in by the ETS remain valid.

- i** When commissioning the actuator for the first time, the parameter should be activated so that the operating mode is initialised to valid scene operating modes.

Presetting scene numbers and scene operating modes

The presetting of the scene number can be defined for each scene of the room temperature controller, by which scene number (1...64) the scene is addressed, i.e. called up or stored.

The data point type of the scene extension object permits addressing of up to 64 scenes max.

In addition to defining the scene number, it must be defined which scene command (Comfort mode, Standby mode, Night mode, Frost/heat protection) is to be set when a scene is called up on the room temperature controller.

Prerequisite

The scene function must be enabled.

- Set the "Scene number" parameter for each scene to the number used to address the scenes.

A scene can be addressed with the configured scene number. A setting of "0" deactivates the corresponding scene so that neither recalling nor storage is possible.

i If the same scene number is configured for several scenes, only the scene with the lowest sequential number will be addressed. The other scenes will be ignored in this case.

- Set the "Operating mode" parameter to the desired operating mode for each scene.

With a scene recall, the configured operating mode is recalled and set at the room temperature controller.

i The configured operating mode is adopted in the actuator during an ETS programming operation only if the parameter "Overwrite values stored in the device during the ETS programming operation" is activated.

Setting the storage behaviour

The operating mode set on the room temperature controller can be stored internally when a scene storage telegram is received via the extension object. The operating mode can be influenced by all functions of the room temperature controller before storage, provided that the individual functions are also enabled.

Prerequisite

The scene function must be enabled.

- Activate the "Storage function" parameter for each scene.

The storage function is activated for the scene in question. On receipt of a storage telegram by means of the "Scenes - Extension unit" object, the current operating mode will be stored internally.

- Deactivate the parameter "storage function" for each scene.

The storage function is deactivated for the scene in question. A storage telegram received via the "Scenes - Extension unit" object will be rejected.

Configuring an extended scene recall

The extended scene recall allows calling of up to 64 scenes of a room temperature controller in sequence. Here, scene recall takes place via the 1-bit communication object "Scenes - Extended scene recall". Each ON telegram received via this object recalls the next of the available scenes in the configuration. Each OFF telegram received recalls the previous scene.

With the extended scene recall, the controller always recalls the neighbouring scene - starting with the scene most recently recalled via the extended recall. It is irrelevant whether the scene is active (scene number = "1...64" or scene active) or inactive (scene number = "0" or scene inactive). If an inactive scene is recalled via the extended scene recall, the room temperature controller will not react.

Only the scenes available in the scene configuration can be selected via the extended scene recall (with "variable" defined by the parameter "number of scenes", with "fixed" always all 64 scenes). After a reset (bus voltage return, ETS programming operation), an ON or OFF telegram always recalls scene 1 first.

Recall of a scene via the 1-byte extension object does not influence the scene sequence of the extended scene recall. The two recall functions work independently of each other.

- Activate the parameter "Extended scene recall".

The object "Scenes - Extended scene recall" is available. Each ON telegram recalls the next scene. Each OFF telegram recalls the previous scene.

- Deactivate the parameter "Extended scene recall".

The extended scene recall is deactivated. A scene recall can only take place via the 1-byte scene extension object.

The extended scene recall can take place with or without an overflow at the scene limits. An overflow occurs when the last scene of the selected configuration is reached when counting up or scene 1 when counting down and an additional telegram in the last counting direction is received by the actuator. The overflow behaviour is defined in the ETS.

- Activate the parameter "with overflow".

After reaching the last scene of the selected configuration, a further ON telegram of the overflow is executed and scene 1 is recalled. Similarly, after reaching scene 1, the overflow is executed by further OFF telegram and the last scene of the selected configuration is recalled.

- Deactivate the parameter "With overflow".

A scene overflow is not possible. After reaching the last scene of the selected configuration, further ON telegrams of the extended scene recall are ignored. In the same way, the actuator ignores further OFF telegrams if scene 1 was recalled last.

11.1.9.1 Scene parameters

FanCoil with controller -> Heating control -> General -> Approvals

Scenes	Active Inactive
This parameter can be used disable or to enable the scene function.	

FanCoil with controller -> Heating control -> General -> Scenes

Delay scene recall	Active Inactive
A scene is recalled via the scene extension object. If required, the scene recall can be delayed on reception of a recall telegram (parameter activated). The recall is alternatively made immediately on reception of the telegram (parameter deactivated).	

Delay time	0 ... 59 min, 0...10...59 s
This parameter specifies the length of the scene delay time. Sets the scene delay time in minutes.	

Overwrite values stored in the device during the ETS programming operation	Active Inactive
During storage of a scene, the scene values are stored internally to memory in the device. To prevent the stored values from being replaced during ETS programming by the originally programmed scene values, the actuator can inhibit overwriting of the scene values (parameter deactivated). As an alternative, the original values can be reloaded into the device during each programming run of the ETS (parameter activated).	

Extended scene recall	Active Inactive
The extended scene recall allows calling of up to 64 scenes of a controller in sequence. Here, scene recall takes place via the 1-bit communication object "Scenes - Extended scene recall". Each ON telegram received via this object recalls the next scene. Each OFF telegram received recalls the previous scene. This parameter enables extended scene recall, if required.	

With overflow	Active Inactive
<p>The extended scene recall can take place with or without an overflow at the scene limits. An overflow occurs when the last scene of the selected configuration is reached when counting up or scene 1 when counting down and an additional telegram in the last counting direction is received by the actuator.</p> <p>Parameter activated: After reaching the last scene of the selected configuration, a further ON telegram of the overflow is executed and scene 1 is recalled. Similarly, after reaching scene 1, the overflow is executed by further OFF telegram and the last scene of the selected configuration is recalled.</p> <p>Parameter deactivated: A scene overflow is not possible. After reaching the last scene of the selected configuration, further ON telegrams of the extended scene recall are ignored. In the same way, the actuator ignores further OFF telegrams if scene 1 was recalled last.</p> <p>This parameter is only visible when the extended scene recall is used.</p>	
Scene configuration	Variable (1 ... 64 scenes) fixed (64 scenes)
<p>The scene configuration selected here decides whether the number of scenes is either variable (1 ... 64) or alternatively fixed to the maximum (64).</p> <p>variable (1...64 scenes): In this setting, the number of scenes used can be selected anywhere within the range of 1 to 64. The parameter "Number of scenes" decides how many scenes are visible for the switching output in the ETS and can therefore be used. It is possible to specify which scene number (1 ... 64) controls each scene.</p> <p>fixed (64 scenes): With this setting, all scenes are always visible and can therefore be used. The scenes are controlled via permanently assigned scene numbers (1 ... 64) (scene number 1 -> scene 1, scene number 2 -> scene 2 ...). If necessary, individual scenes can be deactivated.</p>	
Number of scene assignments	1 ... 10 ... 64
<p>This parameter defines how many scenes are visible for the room temperature controller in the ETS and can therefore be used.</p> <p>This parameter is visible only if the scene configuration is set to "variable".</p>	
Scene number	0 ... 1* ... 64 *: The predefined scene number is dependent on the scene (1...64).
<p>It is possible to preset which scene number (1 ... 64) controls each scene. A setting of "0" deactivates the corresponding scene so that neither recalling nor storage is possible. If the same scene number is configured for several scenes, only the scene with the lowest sequential number will be addressed. The other scenes will be ignored in this case.</p>	

Operating mode	Comfort mode Standby mode Night mode Frost/heat protection mode
This parameter is used for configuring the operating mode which is set when the scene is recalled.	

Memory function	Active Inactive
If the parameter is activated, the storage function of the scene is enabled. The current operating mode can then be stored internally via the extension object on receipt of a storage telegram. If the parameter is deactivated, the storage telegrams are rejected.	

11.1.9.2 Objects for scenes

Function	Name	Type	DPT	Flag
Scenes - Extension unit	RTR ... - Input	1-byte	18,001	C, -, W, -, U
1-byte object for calling or saving a scene.				

Function	Name	Type	DPT	Flag
Scenes - Extended scene recall	RTR ... - Input	1-bit	1,001	C, -, W, -, U
1-bit object for extended scene recall. Each ON telegram received recalls the next scene of a controller in sequence. Each OFF telegram received recalls the previous scene. After a reset (bus voltage return, ETS programming operation), an ON or OFF telegram always recalls scene 1 first.				

11.2 Ventilation control

Introduction

The device contains a fan controller, which allows the fan to be controlled by heating and cooling systems operated by circulating air, such as fan coil units (FanCoil units), depending on a command value calculated in the controller or using manual operation.

The ventilation control can be configured on the "Fan coil with controller -> Ventilation control" parameter page. The number of available fan stages can be parameterised here.

The fan can be configured on the "FanCoil with controller -> Ventilation control -> General" parameter page.

- i** The device is reinitialised after an ETS programming operation or after the bus voltage returns. After initialisation, the fan assumes the state it had before programming or the bus failure. This cannot be parametrised.
- i** The fan control does not work in combination with a 2-point control of the associated heating controller.

Change-over principle

For ventilation control, this device can interact with commercially available fan coil units that operate according to the alternating principle (only one stage output may be switched on - all other stages must be switched off).

When a fan is switched on, there is always only one fan level output active "ON". If the active fan level is changed, the device first switches off the previously switched-on fan level ("OFF" state) and switches on the other output only afterwards.

In this case the "Waiting time when changing the level" parametrised in the ETS is maintained. This means that, when the fan level is changed, the device remains in the "OFF" state for the configured time and switches directly to the specified level only after the time has elapsed.

Example:

Level 3 is active, then switch to level 5 by changing the command value → First fan level output 3 is switched off → Then the device waits for the configured waiting time to elapse → Only after that does it switch directly to level 5.

- i** When the fan is switched on, it is switched directly to the required fan level.

When the fan is switched off, a fan run-on time is executed if configured. Any activated fan level limitation is also taken into account.

Number of fan levels

The device can be adjusted to the specific fan coil application required by means of parameter configurations. The number of fan stages required for the controlled devices can be defined.

Up to five fan levels can be configured to control the fan.

Setting threshold values for command values

To allow the device to evaluate which of the up to five fan levels must be actively set, each fan level is assigned a threshold value of the command value. The assignment is made in the ETS by parametrising a command value (0 ... 100%) per fan level.

As soon as the command value reaches or crosses a threshold value, the device activates the corresponding fan level.

It is recommended that you first set the number of fan speeds.

- Set the "Threshold values" parameter on the "Fan coil with controller -> Ventilation control -> General" parameter page to the required control value. This setting must be made for each fan level.

A fan level switches on when its threshold command value is reached or exceeded. This fan level switches off again as soon as its command value lower limit minus the hysteresis is undershot again.

- i** The following applies: threshold value, level 1 < threshold value, level 2 < ... < threshold value, level 5.
- i** The threshold values for the various fan levels set in the ETS must not be set to identical values, and must not overlap. Otherwise the fan levels will no longer be controlled unambiguously according to their sequence.
- i** The ETS does not catch such configuration errors automatically.

Fan levels and threshold values

In operation, the device converts command values for heating and/or cooling that are received via the bus into equivalent fan levels. The one-byte command value telegrams have a decimal value range of 0...255. This decimal value range is limited to the percentage range of 0% ... 100% command value shown.

Switch-on criterion:

The larger the active control value, the larger the fan speed to be activated by the device. To allow the device to evaluate which of the up to five fan levels of a fan must be actively set, each fan level is assigned a threshold value of the command value. Assignment is made in the ETS by configuring a command value (1...100 %) for each fan level.

As soon as the command value reaches or crosses a threshold value, the device activates the corresponding fan level.

Example (3 fan levels):
Threshold value for fan level 1: 10%,
Threshold value for fan level 2: 30%,
Threshold value for fan level 3: 70%.
Reaction:

Example (3 fan levels):

Active command value 25% → fan level 1 is active.

Now the active command value changes to 35%. → Fan level 2 is active.

Now the active command value changes to 80%. → Fan level 3 is active.

- i** The fan stages are always switched in alternating operation, taking into account the waiting time when switching stages.

As long as the fan is switched off, command values below the threshold value for fan level 1 cause the fan to remain switched off.

Example (3 fan levels):

Threshold value for fan level 1: 10%,

Threshold value for fan level 2: 30%,

Threshold value for fan level 3: 70%.

Reaction:

Active command value is 0% → fan is switched off.

Now the active command value changes to 5%. → Fan remains switched off.

Now the active command value changes to 15%. → Fan level 1 is active.

Now the active command value changes to 35%. → Fan level 2 is active.

Switch-off criterion / hysteresis:

The device takes into account a hysteresis when deactivating fan levels in addition to considering the configured threshold values when activating a fan level. A fan level is only deactivated when the active command value reaches or undershoots the threshold value of the level less the hysteresis derived from the lower limit. The purpose of this behaviour is to prevent constant change-over of the fan levels when the command value is located at the limit between two fan levels.

In addition, when a fan is switched on, command values below the lower limit for fan level 1 minus the hysteresis cause the fan to be switched off. With the command value "0%" the fan switches off in any case.

- i** The hysteresis is only taken into account for deactivation of fan levels, i. e. for switching the fan to a lower level.

The hysteresis is configured in the ETS as a percentage (0...50%) together for all fan levels. The absolute command value that has to be reached or undershot for deactivation of a fan level is derived relatively from each command value lower limit, taking into account the common hysteresis.

Example:

Hysteresis: 5%

Threshold value for fan level 1: 10%,

Threshold value for fan level 2: 30%,

Threshold value for fan level 3: 70%.

Example:**Calculation:**

Command value for deactivation of the fan level = lower limit of level - (lower limit of level * hysteresis)

→ Command value for deactivation of fan level 1 = 10% - (10% * 5%)

→ Command value for deactivation of fan level 1 = 0.1 - (0.1 * 0.05) = 0.1 - (0.005)

→ 0.005 is rounded up to 0.01 (full percentage - corresponds here to 1%)

→ Command value for deactivation of fan level 1 = 0.1 - (0.01) = 10% - 1% = 9%

...

→ Command value for deactivation of fan level 2 = 28%

→ Command value for deactivation of fan level 3 = 66%

Reaction:

Active command value 15% → fan level 1 is active.

Now the active command value changes to 5%. → Fan switches off.

Now the active command value changes to 35%. → Fan level 2 is active.

Now the active command value changes to 29%. → Fan level 2 remains active, because the hysteresis command value for level 2 (28%) was not undershot.

Now the active command value changes to 25%. → Fan level 1 is active.

- i** With the hysteresis setting "0%" the hysteresis is inactive, meaning that a fan level is deactivated immediately when its command value lower limit is undershot.

The following command value diagram (see figure 31) illustrates the evaluation of the lower limits for the fan levels and how the hysteresis is taken into account for a fan level change-over. The diagram is simplified, and does not take into account any waiting times when switching the level (only the active fan level is illustrated), any optional start-up level or any optional fan run-on time.

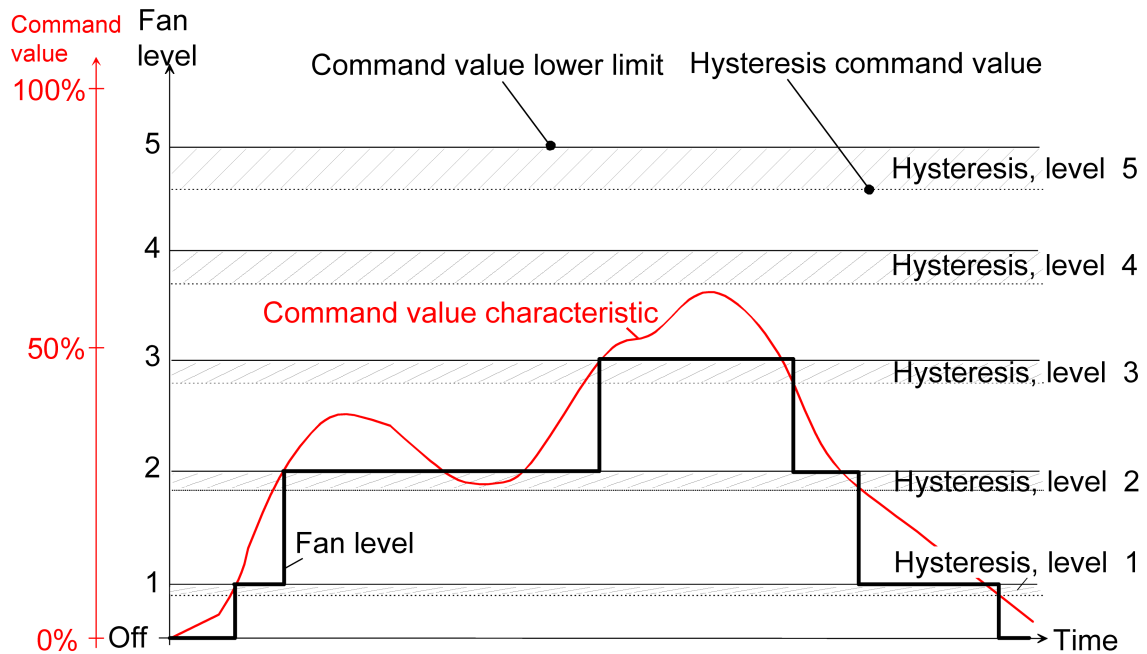

Figure 31: Simplified command value diagram to illustrate a fan level change-over (active fan level), taking into account the command value lower limits and the hysteresis

Setting the hysteresis

A fan level is only deactivated when the active command value reaches or undershoots the lower limit of the level less the hysteresis derived from the lower limit. The hysteresis is set in the ETS only once and is derived relatively from each command value lower limit.

It is recommended that you first set the number of fan speeds.

- Set the parameter "Hysteresis between threshold values (0 ... 50%)" on the parameter page "Fan coil with controller -> Ventilation control -> General" to the required hysteresis.

The set hysteresis affects all of the fan levels relatively. The absolute hysteresis command value is derived individually for each level from its command value lower limit. As soon as the hysteresis command value for a level is undershot, the device deactivates this level.

With the setting "0%", the hysteresis is inactive, meaning that a fan level is deactivated immediately when its command value lower limit is undershot.

Setting the waiting time for level change-over

Pause "OFF" is set separately in the ETS for each fan channel. The pause is visible and effective only for channels with fan level change-over with the change-over principle and when controlled via relay outputs.

It is recommended that you first set the number of fan speeds.

- Set the "Waiting time for level changeover" parameter on the "Fan coil with controller -> Ventilation control -> General" parameter page to the required waiting time.

When the fan level is changed-over, the last fan level output switched on is switched off. The device does not switch on the "new" fan output until the end of the waiting time.

- i** The waiting time for the fan change-over level cannot be deactivated.

Waiting time for level change-over

Due to fan motors' inertia, as a rule there is a limit to how short the time intervals for switching the fan levels can be, i. e. there is a limit to how quickly the fan speed can be varied. Often the technical information for a fan coil unit specifies change-over times that the device must maintain for each fan level change-over. The change-over direction, i. e. whether the level is being increased or decreased, does not play any role here.

When a fan is switched on, there is always only one fan level output active "ON". If the active fan level is changed, a FanCoil actuator first switches off the fan level previously switched-on ("OFF" state), and switches on the other output only afterwards.

In this case the "Waiting time when changing the level" parametrised in the ETS is maintained. This means that, when the fan level is changed, the device remains in the "OFF" state for the configured time and switches directly to the specified level only after the time has elapsed. If new command values are received or specified during the waiting time, the device will switch to the fan level newly specified at the end of the pause time.

If the fan was switched off and is switched on at any level, the device will immediately switch on the corresponding fan output without a pause. Similarly, the fan switches off immediately with no pause in case of a "0" command value or a switch-off command (e. g. disabling function) (if necessary taking into account a fan run-on time).

The following command value diagram (see figure 32) illustrates, as an example, the pause "OFF" waiting time for a fan level change-over with change-over principle. The diagram is simplified and does not take into account any optional start-up level or additional fan run-on time. Moreover, the pause time is shown with an "exaggerated" length in order to convey the switching behaviour better.

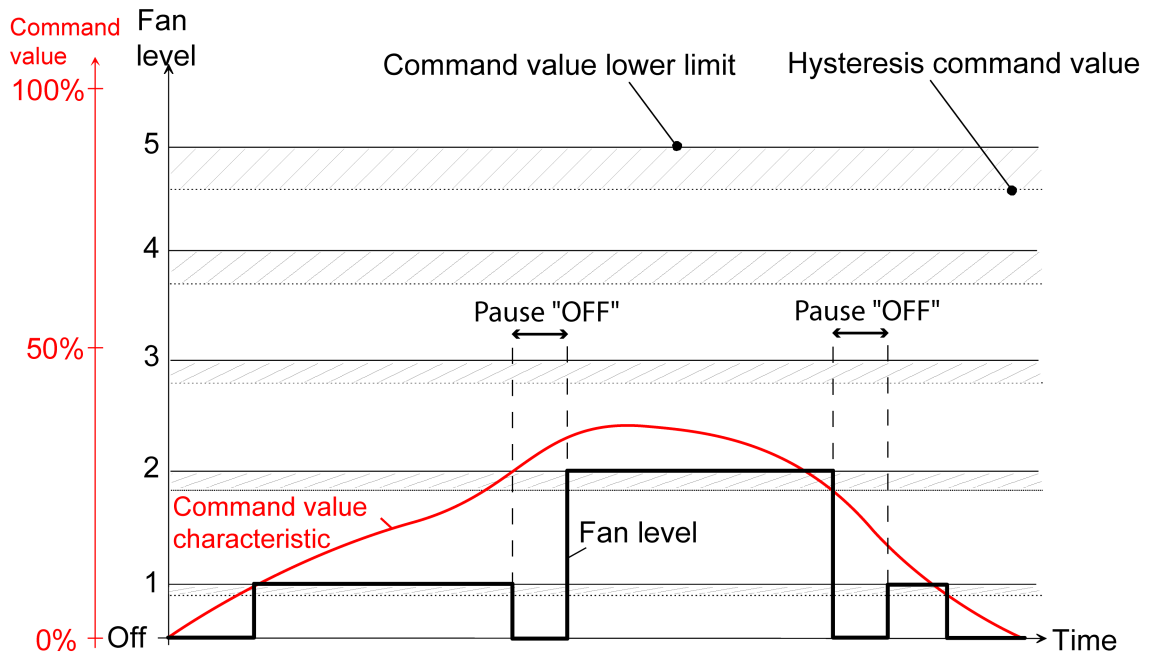

Figure 32: Simplified command value diagram to illustrate a fan level change-over, taking into account the pause "OFF" waiting time

11.2.1 Fan behaviour

The fan behaviour generally determines the reaction when the fan is switched on and off and when there is a level change-over. In addition it is possible to configure a level limitation here.

11.2.1.1 Fan run-on time

To prevent the cooling register from freezing at the end of a cooling process or overheating at the end of a heating process, a run-on time can be configured for the fan in the ETS. A separate run-on time can be parametrised for heating and cooling. The delayed switch-off of the fan means that the air flow through the heat exchanger of the fan coil unit is not stopped immediately. Instead, first only the valve is closed, thus continuing to blow air "through" the heat exchanger of the fan coil unit. The fan does not switch off until after the end of the run-on time.

The fan run-on time is taken into account only if the fan is switched off, for example, by a command value specification of "0".

If the device receives a command value not equal to "0" again within the run-on time or is specified as an active fan level, the run-on time will be aborted and the fan level will remain switched on. Moreover, the run-on time is not retriggered even if additional command values equal to "0" are received.

The following command value diagram (see figure 33) illustrates the fan behaviour after switching off in the operating mode "Cooling", taking a fan run-on time into account. The diagram is simplified, and does not take into account any dwell or waiting time for the level change-over (only the active fan level is illustrated).

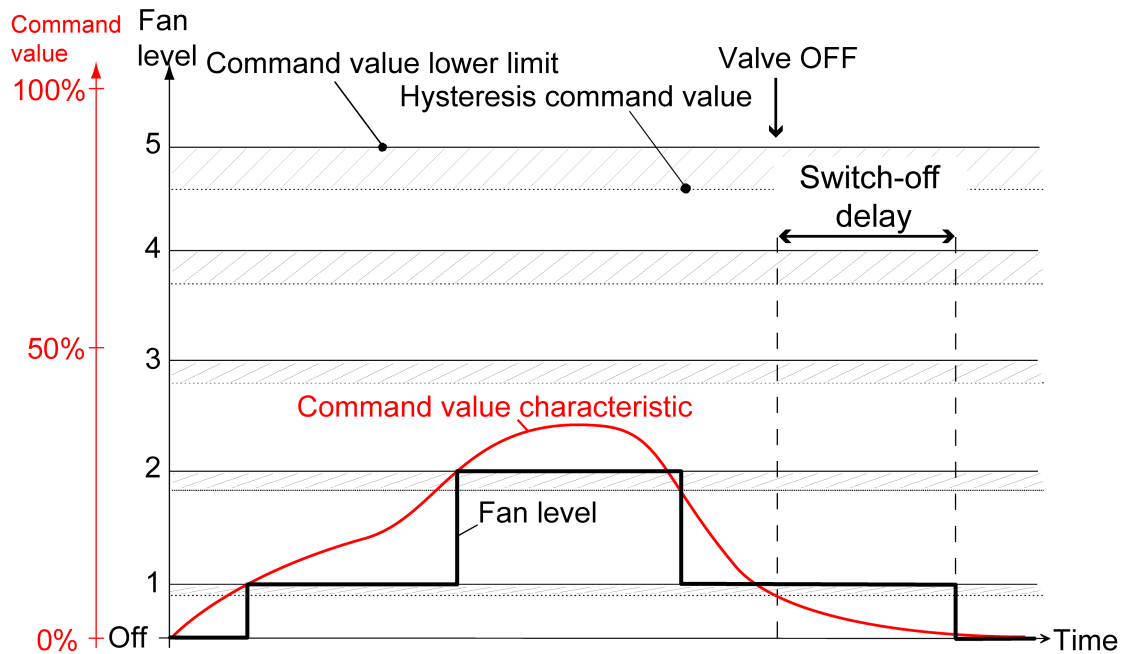

Figure 33: Simplified command value diagram to illustrate a fan level change-over (active fan level), taking into account a run-on time

11.2.1.2 Start-up level

The fan can, if it was switched off before and should now start up, be switched on for a parametrised time at a defined start-up level. This start-up level can be any of the available fan levels, and is set in the ETS using the "Start-up via level" parameter.

- i** The start-up level is generally one of the higher fan levels of a fan coil unit, so that at the beginning of a heating or cooling process the fan can start up correctly (reliable start-up of the fan motor through transfer of a higher torque, and thus a higher fan speed).

The start-up level remains active for the "Dwell time for switch-on level" configured in the ETS. In automatic operation, the controller only switches to the fan level specified by the command value, when the start-up time has elapsed. There is no switching over if, after the start-up time has elapsed, the fan level specified by the command value matches the start-up level.

- i** If the controlled fan requires a longer period of time for the start-up, then the start-up time in the ETS should be configured to higher values.

The start-up level is always taken into account by the fan control in automatic mode on switching the fan on (if it was previously switched off by the command value evaluation) and, in certain situations, also after activation of manual operation. On changing over to manual operation, the behaviour of the fan depends on the settings of the parameter "Fan level on changing over to manual" and "Start-up via level" and the previous fan level in automatic operation as follows.

- If, due to the "Fan level on change-over to manual" parameter, a defined level from level 1 to level 5 is requested, the controller will set this level on activating manual operation. In this case, the parameter "Start-up via level" is not taken into account if the fan was most recently switched off in automatic operation.
- If, due to the "Fan level on change-over to manual" parameter, "Fan level OFF" is requested, the controller will switch the fan off during the change-over to manual operation. On subsequent pressing of the button for manual control, the "Start-up via level" parameter is taken into account and the start-up level set. Then, the controller waits in this level until further manual operation.
- If, due to the "Fan level on change-over to manual" parameter, no defined level is requested ("No change" setting) and the fan was switched off during automatic operation, then it will remain switched off on changing over to manual operation. On subsequent pressing of the button for manual control, the fan is switched to the first level. The "Start-up via level" parameter is thus not taken into account.

i A configured start-up level is applied directly without waiting time.

i With a fan change-over via the 1-bit objects, when the fan level is changed by the controller, the active fan level is first switched off before the new level is switched on. In this case, switching off a fan level and the subsequent changeover to a new fan level is not evaluated as a fan start-up, also meaning that the start-up level is not set. In automatic operation, the start-up level is only taken into account if the fan was switched off previously by the command value evaluation (command value < level 1 threshold value minus hysteresis) and then is to start up using a new command value.

i The start-up via the start-up level also takes place after switching over from manual operation to automatic operation, providing that the fan was most recently switched off in manual operation and, in automatic operation, a new command value requires the fan to be switched on.

Fan level when the fan is switched on (start-up level)

The start-up level has a high priority in the device because it applies to a mechanical property of the connected fan. The start-up level is thus set and executed every time the fan is switched on regardless of whether the fan was switched on by a command value (normal operation) or by manual fan activation. Even when the operating mode is changed (heating ↔ cooling), the start-up level is always executed when the fan is switched on again.

How long the fan runs after it is switched on in the start-up level can be configured in the ETS as a start-up time. The fan remains at the start-up level until the set start-up time has elapsed. Changes in the active fan level, for example via a new command value specification during the start-up time (exception: command value = "0"), do not cause a change-over of the fan level.

Only after the end of the start-up time does it switch to the fan level corresponding either to the last command value specified or to the direct fan level specified.

The following command value diagram (see figure 34) illustrates the fan behaviour after switching on, taking a start-up level into account. The diagram is simplified, and does not take into account any dwell or waiting time for the level change-over (only the active fan level is illustrated), optional start-up level or additional fan run-on time.

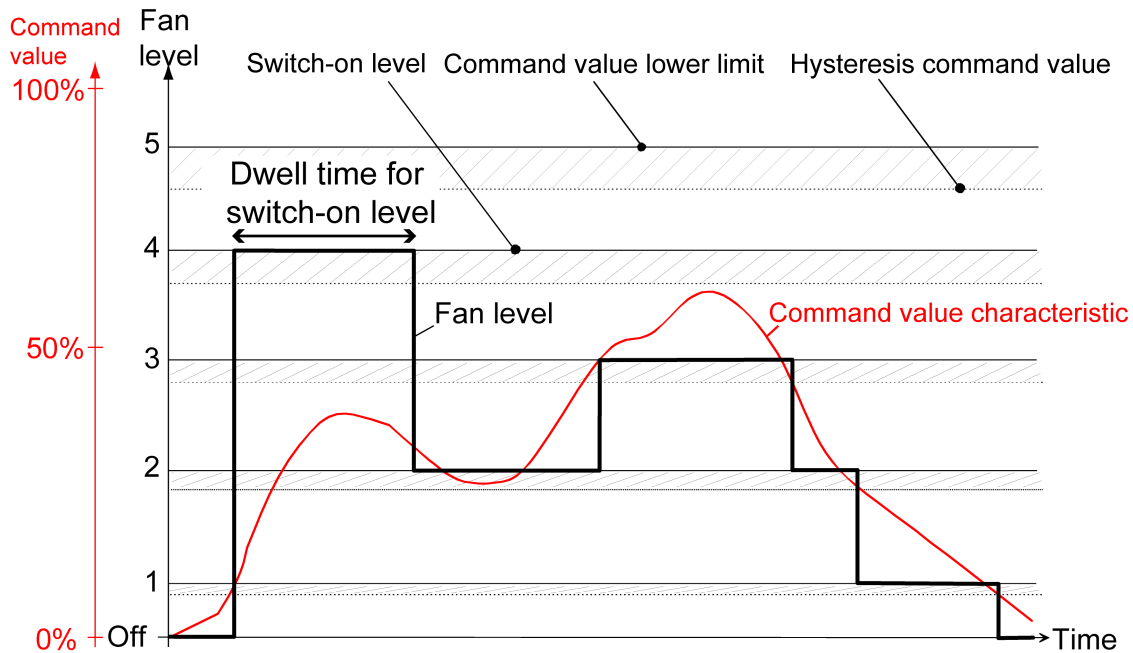

Figure 34: Simplified command value diagram to illustrate a fan level change-over (active fan level), taking into account the start-up level

11.2.1.3 Fan level limit

To reduce the fan noise of a fan coil, the fan level limit can be activated. The level limit reduces the sound emissions by limiting the maximum fan level to a fan level value specified in the ETS by the "Level limit" parameter (limit level). The limit can be switched on and off via the 1-bit object "Level limit - Activation/deactivation", and thus activated in accordance with requirements, for example via a timer during night-time hours in order to reduce noise in bedrooms, or via "manual" operation of a push-button sensor when a "quiet room" is needed (auditorium or the like). The limitation of the fan level is activated by receipt of a "1" telegram via the object "Level limitation - Activation/deactivation". Deactivation is therefore achieved by receiving a "0" telegram.

While a limitation is active, the fan controller prevents the fan from being switched to a higher level than the limitation level. If, at the instant that the limit is activated, the fan is running at a level that is greater than the limit level, then the fan level is immediately reduced to the limitation value. In this case, the switching sequence of the individual levels and the waiting time configured in the ETS are also taken into account in the level switchover.

The limitation level can be one of the available fan levels.

The level controller distinguishes between Automatic and Manual operation.

- i** The fan level limit overrides the start-up level. As a result, when the fan is switched on, if the limit is active, the level has an active limit and the start-up level is not approached. In this case, the limit level is jumped to without waiting.
- i** The level limit has no effect with an activated fan forced position.
- i** The parameter "Level limit" is not checked for plausibility, meaning that an incorrect configuration is possible. For this reason, care should be taken to ensure that there is no limit level in the configuration which is higher than the actual fan levels. If a higher limit level is configured, then the limit has no effect.

Level limitation

To reduce the fan noise of a fan coil, the fan level limit can be activated. The level limitation reduces the sound emissions by limiting the maximum fan level to a fan level value specified in the ETS (limitation level). The limitation can be switched on and off by means of a 1-bit communication object via the bus, and thus activated in accordance with requirements, for example by a timer during nighttime hours to reduce the noise in bedrooms, or by "manual" operation of a push-button sensor when a "quiet room" (auditorium etc.) is required.

The limitation of the fan level is activated by receipt of a "1" telegram via the object "Level limitation - Activation/deactivation". Deactivation is therefore achieved by receiving a "0" telegram.

While a limitation is active, the device prevents the fan from being switched to a higher level than the limitation level. If at the instant that the limitation is activated the fan is running at a level that is greater than the limitation level, then the fan level is immediately reduced to the limitation value. In this case the dwell time or the pause "OFF" is also taken into account in the level change-over. When the fan is switched on, however, reduction to the limitation value is only performed after any start-up level that may be active has been processed.

The limitation level can be one of the available lower fan levels; the largest fan level cannot be selected.

The level limitation has an effect on the following functions...

- Fan level control via the bus by means of regular command value telegrams,
- Manual fan control,
- Fan protection.

Fan level limitation has no effect on...

- a start-up level.

After deactivation of one of these functions with higher priority, a level limitation is taken into account if the limitation is activated at that instant.

After an effective level limitation has been deactivated via the object, the device sets the non-limited setpoint fan level for the channel concerned, thus increasing the fan level directly if necessary. In this case, if the fan was switched off and switched on again via the level limitation, a start-up level is also executed, provided that it is parametrised.

The following command value diagram (see figure 35) illustrates by means of an example the reaction to a level limitation for an active fan level that is above the limitation level. The diagram is simplified and does not take into account any dwell or pause times when changing the fan level or any optional start-up speed or additional fan run-on time.

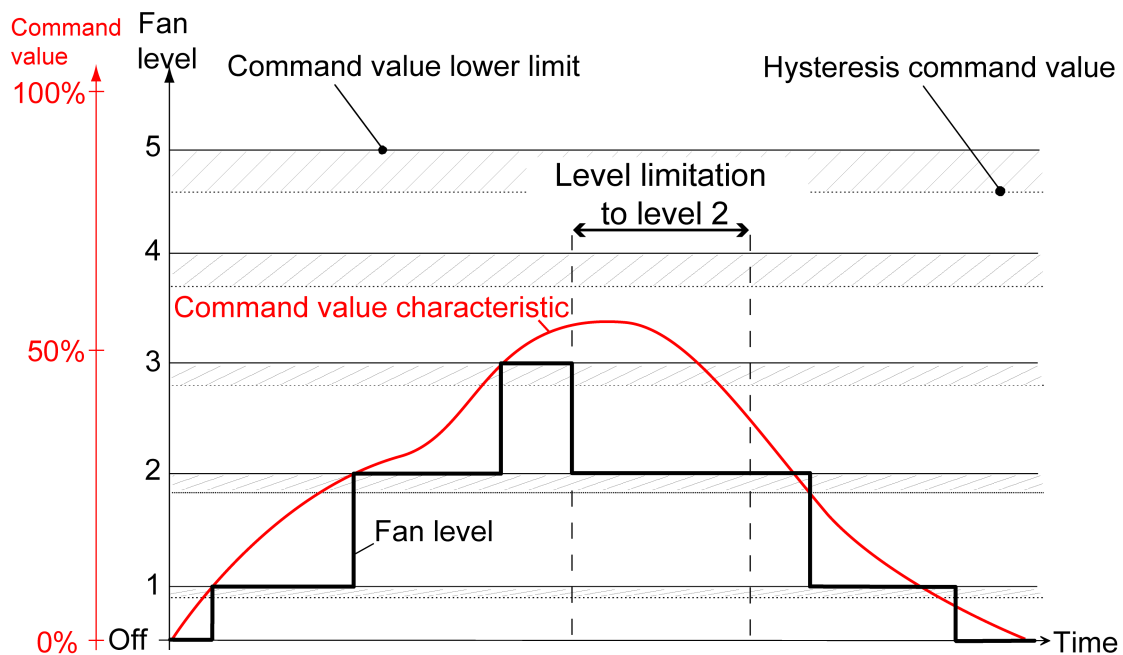

Figure 35: Simplified command value diagram to illustrate the reaction to a fan level limitation

11.2.1.4 Forced fan position

The controller provides the option of activating a forced fan position via the bus. With an active forced position, the fan levels can neither be controlled nor switched over in either automatic or manual mode. The fan remains in the forced state until the forced position is removed using the bus. In this manner, it is possible to switch the fan to a locked and controlled state, for example for servicing purposes.

As soon as a "1" telegram is received via the 1-bit object "Forced position - Activation/deactivation", the controller immediately sets the fan level configured in the ETS without delay. The fan can also be completely switched off. The only special feature when activating the forced position is the fact

that the fan controller is in automatic operation and a waiting time elapses, due to a previous level change-over. In this case, the fan controller only switches to the forced position level without the waiting time elapsing.

- i** The forced position is dominant. For this reason, it can be overdriven from automatic mode, manual mode, the level limit or fan protection. Only when the forced position is removed does the fan control begin to control the fan levels according to the active operating mode.

The removal takes place when a "0" telegram is received via the "Forced position - Activation/deactivation" object. The fan always switches itself off first. In automatic operation, the controller then evaluates the active command value and, when the waiting time configured in the ETS has elapsed, switches to the required fan level, taking an optionally configured start-up level into account. In manual operation, the fan first remains switched off. The fan level is only raised when the manual control button is pressed again. If a start-up level is configured, the controller will, when a button is pressed, switch to the start-up level and remain there until further operation takes place.

- i** The parameter "Behaviour in a forced position" is not checked for plausibility, meaning that an incorrect configuration is possible. For this reason, care should be taken to ensure that there is no fan level in the configuration which is higher than the actual fan levels. If a higher level is configured for behaviour in a forced position than the number of fan levels, then the fan controller will start up the maximum possible level when the forced position is activated.
- i** The forced fan position does not influence the control algorithm integrated in the controller. The command values of the PI feedback control continue to be transmitted to the bus, even with a forced fan.

11.2.1.5 Fan protection

The fan protection function allows the fan of a fan coil unit, which has not been active for some time, to be temporarily switched to the maximum level. In this way, the fan controller fan motors can be protected against stiffness. In addition, the fan blades and the heat exchanger of the fan coil unit are protected against dust.

If the fan protection is to be used, it must be enabled using the parameter of the same name in the ETS. Fan protection can then be activated or deactivated directly using the 1-bit communication object "Fan protection - Activate/deactivate", for example using a KNX timer.

If the fan protection object has the switching value "1", then the fan protection function is active. The fan then works at the highest possible fan level and overdrives automatic and manual operation. Fan protection can then be switched off again using the "0" switching value in the communication object.

The reaction of the fan to switching fan protection depends on the operating mode of the automatic fan system. In automatic operation, the fan switches back to the level determined by the command value of the room temperature control. In manual operation, the fan switches off and can then be switched on again by additional manual actuation. The "Start-up via level" parameter is taken into account here.

- i** Even if the fan controller is inactive, it is possible to activate the fan using fan protection.
- i** With an active level limit, the maximum fan level of fan protection is specified by the limit level.
- i** For reasons of safety, fan protection is not carried out with an active forced position.
- i** The run-on times of the fan do not take effect with fan protection.

11.2.2 Fan control parameters

FanCoil with controller -> Ventilation control -> General

Name of the fan	40-character free text
<p>The text entered in this parameter is used to label the controller in the ETS parameter window (e. g. "FanCoil kitchen", "Bathroom fan"). The text is not programmed in the device.</p> <p>A designation has already been preset, depending on the parameterisation of the device. The designation is made up of the channel number, the operating mode and the type of control.</p>	

Ventilation control

Operating mode	Heating
<p>The available selection of adjustable parameter values for this parameter is directly dependent on the parameter setting for the "Operating mode" parameter on the "Fan coil with controller" parameter page.</p> <p>This parameter is used to specify the operating mode of the ventilation control.</p>	

Operating mode	Cooling
<p>The available selection of adjustable parameter values for this parameter is directly dependent on the parameter setting for the "Operating mode" parameter on the "Fan coil with controller" parameter page.</p> <p>This parameter is used to specify the operating mode of the ventilation control.</p>	

Operating mode	Heating Cooling Heating and cooling
<p>The available selection of adjustable parameter values for this parameter is directly dependent on the parameter setting for the "Operating mode" parameter on the "Fan coil with controller" parameter page.</p> <p>This parameter is used to specify the operating mode of the ventilation control.</p>	

Operating mode	Basic heating Additional heating
<p>The available selection of adjustable parameter values for this parameter is directly dependent on the parameter setting for the "Operating mode" parameter on the "Fan coil with controller" parameter page.</p> <p>This parameter is used to specify the operating mode of the ventilation control.</p>	

Operating mode	Basic cooling Additional cooling
<p>The available selection of adjustable parameter values for this parameter is directly dependent on the parameter setting for the "Operating mode" parameter on the "Fan coil with controller" parameter page.</p> <p>This parameter is used to specify the operating mode of the ventilation control.</p>	

Operating mode	Basic heating Additional heating Basic cooling Additional cooling Basic heating and cooling Basic heating and additional cooling Basic cooling and additional heating Additional heating and cooling
----------------	--

The available selection of adjustable parameter values for this parameter is directly dependent on the parameter setting for the "Operating mode" parameter on the "Fan coil with controller" parameter page.

This parameter is used to specify the operating mode of the ventilation control.

Number of fan levels	1... 3 ...5
A maximum of 5 fan levels can be used. With this setting the required fan levels and the associated parameters are defined in the ETS.	

Fan level switchover via	Switching objects (1 bit per fan speed) Value object (1-byte)
The fan speed is switched either via up to five 1-bit switching objects or via a 1-byte value object.	

Specification / _visualization_ fan level	Value object (DPT 5.100 0 ... 255) Value object (DPT 5.001 0 ... 100%)
The fan speed can be specified and visualised via a value object either in the value range 0 ... 255 or 0 ... 100%. This parameter influences the communication objects "Fan speed - Status - Current level", "Fan speed - Forced position - Default", "Fan speed - Manual operation - Default" and "Fan speed - Status - Setpoint level".	

Thresholds

OFF -> Level 1	0... 10 ...100
As a transition between the levels, there are threshold values, defined according to the command value of the controller, which can be set here. If the command value reaches the threshold value of a level during an increase of the command value, the appropriate level is activated. If the command value reaches below a threshold value, minus the configured hysteresis, during a reduction of the command value, then the switchover takes place into the next lowest fan level.	

Level 1 -> Level 2	0 ... 30...100
As a transition between the levels, there are threshold values, defined according to the command value of the controller, which can be set here. If the command value reaches the threshold value of a level during an increase of the command value, the appropriate level is activated. If the command value reaches below a threshold value, minus the configured hysteresis, during a reduction of the command value, then the switchover takes place into the next lowest fan level.	
Level 2 -> Level 3	0 ... 60...100
As a transition between the levels, there are threshold values, defined according to the command value of the controller, which can be set here. If the command value reaches the threshold value of a level during an increase of the command value, the appropriate level is activated. If the command value reaches below a threshold value, minus the configured hysteresis, during a reduction of the command value, then the switchover takes place into the next lowest fan level.	
Level 3 -> Level 4	0 ... 90...100
As a transition between the levels, there are threshold values, defined according to the command value of the controller, which can be set here. If the command value reaches the threshold value of a level during an increase of the command value, the appropriate level is activated. If the command value reaches below a threshold value, minus the configured hysteresis, during a reduction of the command value, then the switchover takes place into the next lowest fan level.	
Level 4 -> Level 5	0 ... 100
As a transition between the levels, there are threshold values, defined according to the command value of the controller, which can be set here. If the command value reaches the threshold value of a level during an increase of the command value, the appropriate level is activated. If the command value reaches below a threshold value, minus the configured hysteresis, during a reduction of the command value, then the switchover takes place into the next lowest fan level.	
Hysteresis between threshold values	0...3...50%
If the command value of the room temperature control has undershot the threshold value minus the hysteresis, the fan controller switches back to the next lower level.	
Waiting time for level change-over	0...25 s 100...200...900 ms
Due to fan motors' inertia, as a rule there is a limit to how short the time intervals for switching the fan levels can be, i. e. there is a limit to how quickly the fan speed can be varied. The old fan speed is switched off before the new fan speed is switched on. The "waiting time when switching the level" can be set here. If the threshold value is exceeded or undershot and the old fan level has been switched off, the timer for the waiting time will start. The device only switches the new fan level automatically when the waiting time has elapsed.	

Switch-over behaviour when changing by several fan speeds	<p>switch directly to new level Switch through intermediate stages</p>
<p>This parameter is used to set the behaviour when changing the level in the event of a large deviation of the current command value. If the new command value is so large that it should not be switched to the next stage, but directly to the next but one, this parameter can also be used to specify the start of the intermediate stages.</p>	
Fan level on change-over to manual	<p>No change Fan level 1 Fan level 2 Fan level 3 Fan level 4 Fan level 5 Fan level OFF</p>
<p>If manual mode is switched to, this parameter determines whether the fan remains at the same fan level, a predefined fan level is switched on or the fan is switched off.</p> <p>i You can switch to manual mode only in comfort operating mode.</p>	
Level limit (max. fan level)	<p>No level limit Fan level 1 Fan level 2 Fan level 3 Fan level 4</p>
<p>To reduce the fan noise of a fan coil, the fan level limit can be activated. The selectable fan level depends on the parametrised maximum fan level. The level limit reduces the sound emissions by limiting the maximum fan level to a fan level value configured here (limitation level). The limit can be switched on and off using the "Level limit – Activate/deactivate" 1-bit object and thus activated as required.</p>	
Behaviour on forced position	<p>No forced position Fan level 1 Fan level 2 Fan level 3 Fan level 4 Fan level 5 Fan level OFF</p>
<p>A controller provides the option of activating a forced fan position via the bus. With an active forced position, the fan levels can neither be controlled nor switched over in either automatic or manual mode. The fan remains in the forced state until the forced position is removed using the bus. In this manner, it is possible to switch the fan to a locked and controlled state, for example for servicing purposes. The selectable fan level depends on the parametrised maximum fan level.</p>	

Object polarity fan levels	0 = automatic / 1 = manual 1 = automatic / 0 = manual
The parameter specifies the polarity of the object for the change-over between automatic and manual fan control. Automatic mode is always active after a device reset. The setting made here also applies to the "Auto/Manual - Status" status object.	
Heating fan run-on time	0 ... 4 min, 0 ... 59 s
If the fan is switched-off in automatic or manual operation, it runs on for the time configured at this point, provided that a factor of more than "0" is set. This parameter applies to the controller operating mode "Heating".	
Cooling fan run-on time	0 ... 4 min, 0 ... 15 ... 59 s
If the fan is switched-off in automatic or manual operation, it runs on for the time configured at this point, provided that a factor of more than "0" is set. This parameter applies to the controller operating mode "Cooling".	
Fan protection	Active Inactive
The fan protection function allows the fan of a fan coil unit, which has not been active for some time, to be temporarily switched to the maximum level. In this way, the controller fan motors can be protected against stiffness. In addition, the fan blades and the heat exchanger of the fan coil unit are protected against dust against dust. If the fan protection is to be used, it must be activated at this point.	
Start-up using level	Fan level 1 Fan level 2 Fan level 3 Fan level 4 Fan level 5
The fan can, if it was switched off before and should now start up, be switched on at a defined start-up level. This start-up level can be any of the available fan levels, and is set using this parameter. The start-up level is usually one of the higher fan levels of a fan coil unit. The start-up level remains active for the "start-up time" configured in the ETS.	
Dwell time for switch-on level	0...15...25 s, 0...900 ms
Fan motors require a design-related time to reach the rated speed. This parameter can be used to adjust the start-up time to the fan used in order to optimise the switch-on behaviour.	

Fan speed status object	Active Inactive
<p>The device can report the active fan level to the bus separately for each FanCoil channel. In this manner the state of the fan coil can be transmitted to the bus at any time and displayed in a visualisation or evaluated further in other bus devices, for example.</p> <p>As soon as the fan level changes, the 1-byte communication object "Fan level - Status - Current level" is updated.</p>	
Automatic fan status object	Active Inactive
<p>The device can report back to the bus separately for each FanCoil channel on whether the fan is in manual or automatic mode. In this manner the state of the fan coil can be transmitted to the bus at any time and displayed in a visualisation or evaluated further in other bus devices, for example.</p> <p>As soon as you switch to manual or automatic mode, the one-bit communication object "Auto/manual - Status" changes. The parametrised object polarity is taken into account.</p>	
Command value is 0%, until preset command value is greater than	0 ... 1...100%
<p>The command value evaluated by the fan controller in automatic operation can be optionally limited by this parameter in the bottom command value range. In this case, the controller evaluates command values which fall short of the configured limit value as 0%. This means that the fan stands still even at minimum command values.</p>	
Command value is 100%, as soon as internal command value is greater than	0...99...100%
<p>The command value evaluated by the fan controller in Automatic mode can be optionally limited by this parameter in the top command value range. In this case, the controller evaluates command values which exceed the configured limiting value as 100%. This means that the fan works at full power even with command values not at the maximum.</p>	
Command value offset	0 ... 100%
<p>The command value evaluated by the fan controller in Automatic mode can be optionally raised by the static offset configured here. Should the calculation produce a value of over 100 %, then the command value is limited to the maximum value.</p>	

Fan behaviour in standby operating mode	Automatic mode Automatic (min. level 1) Automatic (min. level 2) Automatic (min. level 3) Automatic (min. level 4) Fixed level OFF Fixed level 1 Fixed level 2 Fixed level 3 Fixed level 4 Fixed level 5
---	---

The parameter determines the fan level when changing to standby mode. Automatic mode is always active after a device reset.

The displayed selection of fan levels depends on the parametrised number of fan levels.

Fan behaviour night operating mode	Automatic mode Automatic (min. level 1) Automatic (min. level 2) Automatic (min. level 3) Automatic (min. level 4) Fixed level OFF Fixed level 1 Fixed level 2 Fixed level 3 Fixed level 4 Fixed level 5
------------------------------------	---

The parameter determines the fan speed when changing to night mode. Automatic mode is always active after a device reset.

The displayed selection of fan levels depends on the parametrised number of fan levels.

11.2.3 Fan control objects

Function	Name	Type	DPT	Flag
Fan level – Status – Current level	FanCoil - Output	1-byte	5,100	C, R, -, T, A
1-byte object for feeding back the current fan level.				

Function	Name	Type	DPT	Flag
Fan speed - Status - Current level	FanCoil - Output	1-byte	5,001	C, R, -, T, A
One-byte object for feedback of the current fan speed. The fan speed is a percentage of the current fan level to which the fan has been switched.				

Function	Name	Type	DPT	Flag
Fan level - Status - Set speed	FanCoil - Output	1-byte	5,100	C, R, -, T, A
1-byte object for feeding back the current nominal fan level.				

Function	Name	Type	DPT	Flag
Fan level - Status - Set speed	FanCoil - Output	1-byte	5,001	C, R, -, T, A
1-byte object for feeding back the current nominal fan level.				

Function	Name	Type	DPT	Flag
Auto/manual - Switching	FanCoil - Input	1-bit	1,003	C, -, W, T, U
1-bit object for activating and deactivating manual fan control. The fan control can be switched to either manual or automatic mode by means of this object, depending on the parametrisation. You can switch to manual mode only in comfort operating mode.				

Function	Name	Type	DPT	Flag
Auto/manual - Status	FanCoil - Output	1-bit	1,001	C, R, -, T, A-
One-bit object for status feedback for manual control. The object polarity can be configured.				

Function	Name	Type	DPT	Flag
Fan level – Manual operation – Default	FanCoil - Input	1-byte	5,100	C, R, W, -, A
1-byte object for direct specification of the fan level in manual fan control. Value range: 0 ... max. 5. The maximum value is limited by the number of configured fan levels. Values greater than the maximum fan level are interpreted by the actuator like the maximum value.				

Function	Name	Type	DPT	Flag
Fan speed – Manual operation – Preset	FanCoil - Input	1-byte	5,001	C, R, W, -, A
<p>1-byte object for direct specification of the fan speed in manual fan control. Value range: 0 ... 100%. The device converts the percentage into fan levels. The following applies 0% = fan off 1% ... = fan level 1 ... 100% = highest fan level depending on the parametrised number of fan levels, there is a proportional assignment between the percentage and the fan level . The threshold values parametrised in the ETS apply only to automatic mode and have no influence on the fan levels in manual mode.</p>				
Function	Name	Type	DPT	Flag
Fan protection – Activate/deactivate	FanCoil - Input	1-bit	1,001	C, -, W, -, U
<p>One-bit object used to activate the fan protection. Polarity: "0" = fan protection disabled / "1" = fan protection activated.</p>				
Function	Name	Type	DPT	Flag
Forced position - Activate/Deactivate	FanCoil - Input	1-bit	1,001	C, -, W, -, U
<p>1-bit object used to activate or deactivate the forced position of the fan control</p>				
Function	Name	Type	DPT	Flag
Fan speed - Forced position - Setting	FanCoil - Input	1-byte	5,001	C, -, W, -, U
<p>1-byte object used to specify the force-controlled fan level.</p>				
Function	Name	Type	DPT	Flag
Fan speed - Forced position - Setting	FanCoil - Input	1-byte	5,100	C, -, W, -, U
<p>1-byte object used to specify the force-controlled fan level.</p>				
Function	Name	Type	DPT	Flag
Level limit – Activate/deactivate	FanCoil - Input	1-bit	1,001	C, -, W, -, U
<p>1-bit object for activating and deactivating the level limitation. Polarity: "0" = level limitation deactivated / "1" = level limitation activated.</p>				
Function	Name	Type	DPT	Flag
Fan level - Manual operation - Status	FanCoil - Output	1-byte	5,100	C, R, -, T, A
<p>One-byte object for feeding back the active manual fan level.</p>				

Function	Name	Type	DPT	Flag
Fan speed - Manual operation - Status	FanCoil - Output	1-byte	5,001	C, R, -, T, A
One-byte object for feeding back the active manual fan speed. Because the device works only with fan levels in manual mode, the highest percentage of the currently active fan level is displayed as the status.				

Function	Name	Type	DPT	Flag
Fan level 1 - Status	FanCoil - Output	1-bit	1,001	C, R, -, T, A
1-bit object used to feed back the active fan level.				

Function	Name	Type	DPT	Flag
Fan level 2 - Status	FanCoil - Output	1-bit	1,001	C, R, -, T, A
1-bit object used to feed back the active fan level.				

Function	Name	Type	DPT	Flag
Fan level 3 - Status	FanCoil - Output	1-bit	1,001	C, R, -, T, A
1-bit object used to feed back the active fan level.				

Function	Name	Type	DPT	Flag
Fan level 4 - Status	FanCoil - Output	1-bit	1,001	C, R, -, T, A
1-bit object used to feed back the active fan level.				

Function	Name	Type	DPT	Flag
Fan level 5 - Status	FanCoil - Output	1-bit	1,001	C, R, -, T, A
1-bit object used to feed back the active fan level.				

12 Air conditioning/split unit

Introduction

The device can be used for extension unit operation, allowing central heating control devices with an integrated room temperature controller or split unit gateways to be controlled.

In this configuration, the device itself is not involved in temperature control.

Split unit gateways room temperature controllers typically allow the room temperature control to be influenced in different ways. These include the options of operating mode switching, setpoint temperature shifting, switching between automatic or manual fan control and manual specification of a fan speed.

In extension unit mode, the device is operated via the control panels. Device components.

The control panels can be used to fully control a split unit or a room temperature controller by changing the operating mode, adjusting the setpoint temperature, specifying the fan control (auto or manual) or manually specifying the fan speed.

12.1 Setpoint shift

In extension unit mode, the device offers the option of specifying a setpoint value for the setpoint temperature.

The setpoint can be specified either via an absolute temperature value specification or via a relative temperature value shift.

Operation

With the setpoint temperature shift, the setpoint value is specified using the "-" and "+" buttons. If the "+" or "-" button is pressed and held (>1 s), the setpoint is set with 3 increments per second.

If the setpoint is not adjusted again within 3 seconds of the last operation or if the menu button is pressed, the changed setpoint temperature is sent to the controller via the bus.

Status feedback

As soon as the change is confirmed to the device via the status object, the confirmation of the setpoint change is confirmed by a double flashing setpoint temperature in the display. If a different setpoint temperature is reported back via the status object, this different setpoint temperature is adopted in the device and confirmed with a double flash in the display.

If the setpoint temperature is adjusted on the device in such a way that there is no change in the setpoint specification, confirmation of the setpoint setting is confirmed by a double flashing setpoint temperature in the display, but is not sent to the bus. This means that there is no change in the setpoint temperature at the start of operation.

After specifying a setpoint using the "-" and "+" buttons and sending the new setpoint temperature to the bus, the device expects feedback via the status setpoint object. If this feedback does not occur automatically within 10 seconds, the device sends a read request for the setpoint temperature to the bus. If there is again no response after 10 seconds, the display shows an error "--" in the secondary segment instead of the setpoint temperature.

In the event of an error, each time the "-" and "+" buttons are pressed again, the device sends the last setpoint temperature sent, but not yet confirmed, to the bus. Only after the setpoint temperature has been confirmed can it be adjusted again using the "-" and "+" buttons.

In the event that a new setpoint temperature is received without prior operation of the "-" and "+" buttons on the device, this new setpoint temperature is shown in the secondary segment of the display. For example, the desired temperature can change when the operating mode is changed.

Absolute temperature value specification

With absolute temperature value specification, the setpoint is specified using the "-" and "+" buttons in fixed increments of 1 °C. If the "+" or "-" button is pressed and held (>1 s), the setpoint is set with 3 increments per second (= 3 °C).

- i** The secondary segment of the display shows setpoint temperatures in 0.5 °C increments. In the case of setpoint specifications via the bus, the displayed setpoint temperature is rounded if changes to the setpoint temperature are made elsewhere in 0.1 °C increments.

Relative temperature value shift

With the relative temperature value shift, the shift takes place according to the parameterisation via count value x step value or via relative temperature values.

The device supports the setpoint shift via count value function (count value x step value). The communication objects for the temperature shift are then of data point type 6.010.

When a temperature difference is received, the device always calculates from the "Setpoint temperature - active operating mode". If the "Setpoint temperature - active operating mode" is 21 °C, for example, a value of "-2" is sent to the bus via the communication object when the "-" button is pressed twice. This results in a setpoint temperature of 19 °C. Accordingly, the display shows the setpoint values of 20 °C -> 19 °C during operation.

The device supports the setpoint shift function using temperature differences (relative temperature values). The communication objects for the temperature shift are then of data point type 9.002.

When a temperature difference is received, the device always calculates from the "Setpoint temperature - active operating mode". If the "Setpoint temperature - active operating mode" is 21 °C, for example, a value of "-2 K" is sent to the bus via the communication object when the "-" button is pressed twice. This results in a setpoint temperature of 19 °C. Accordingly, the display shows the setpoint values of 20 °C -> 19 °C during operation.

The increment results from the operation.

- i** The correct setpoint temperature of the active operating mode is required for the relative temperature value shift function. This must be transmitted to the device via the "Setpoint temperature - Active operating mode" communication object when changing operating mode, among other things.

12.2 Operating mode switchover

As an air conditioning/split unit, the device can switch between different operating modes at the touch of a button or via the bus.

Different operating modes are switched, each of which is assigned different setpoint temperatures and properties in the controller.

The type of operating modes can be adapted to the main unit using parameters. The adjustment is made via the "Configuration objects" parameter.

A split unit can be controlled either via a central 1-byte communication object or via individual 1-bit communication objects.

A fan coil unit can also be controlled via a central 1-byte communication object.

The following table shows the available operating modes.

Split unit: HVAC modes (DPT 20.105)	Split unit: 1-bit objects	FanCoil: HVAC mode (DPT 20.102)
Automatic mode	Automatic mode	Comfort
Heating	Heating	Standby
Cooling	Cooling	Night
Ventilating	Ventilating	
Dehumidify	Dehumidify	
Eco	Eco	
Boost	Boost	

Depending on the setting of the "Configuration objects" parameter, the ETS provides suitable communication objects and parameters.

- i** The prerequisite for the device to be able to switch between different operating modes is that the "Show operating mode on display" parameter is parameterised as active and the active operating mode is therefore shown on the display.

Operating mode switchover by pressing a button

The current operating modes are shown on the display. These operating modes can be switched using the menu button. If an operating mode is selected, the device sends the change to the bus three seconds after switching via the menu button.

To configure the split unit, the individual operating modes that can be switched between must be selected in the ETS using parameters.

Switching via the menu button takes place in the Split Unit configuration in the sequence "Automatic -> Heating -> Cooling -> Ventilation -> Dehumidification -> Eco -> Boost".

Switching via the menu button takes place in the FanCoil configuration according to the parameterised switching behaviour.

Operating mode switchover by means of object

Depending on the setting of the "Configuration objects" parameter, the operating mode to be set is specified via the central 1-byte or the individual 1-bit communication objects.

12.3 Fan adjustment

Auto/manual fan control

Automatic mode activation, manual control activation or auto/manual switchover. (DPT 1.003)

Manual fan preset

Fan level specification in data point type level "DPT 1.007" 0/1 | Value range "DPT 5.001 | 0 ... 100%" or "DPT 5.100 | 0 ... 255" or . The value adjustment can optionally be configured by long pressing of the button.

12.4 Air conditioning / split unit parameter

"Air conditioning/split unit" parameter page

Setpoint presetting	absolute temperature value specification relative temperature value shift
<p>It is possible to configure the setpoints directly (absolute setpoint presetting) or relatively (derivation from basic setpoint). This parameter defines the way the setpoint temperature is preset.</p> <p>With "relative", all temperature setpoints are derived from the basic temperature (basic setpoint).</p> <p>With "Absolute": The setpoint temperatures are independent of each other. Different temperature values can be specified for each operating mode and heating/cooling mode.</p>	
Type of shift	Counting value x increment relative temperature value
<p>Depending on the setting of the parameter "Type of shift", the shift takes place via a 2-byte communication object according to KNX DPT 9.002 or via a 1-byte communication object according to KNX DPT 6.010.</p>	
Show operating mode on the display	Active Inactive
<p>This parameter enables the active operating mode to be shown on the indicator.</p> <p>This parameter enables the communication objects for switching the operating mode.</p> <p>This parameter activates the boost function of the air conditioning/split unit.</p> <p>When active: The device can switch the operating mode of the air conditioning/split unit via communication objects and shows the currently active operating mode on the display. The boost function can be parameterised.</p> <p>When inactive: The operating mode switchover by the device is deactivated. The device does not show the currently active operating mode of the air conditioning/split unit on the display. No boost function can be parameterised.</p>	
Operating mode switchable at the touch of a button	Active Inactive
<p>This parameter enables the operating mode to be switched on the device.</p> <p>When active: The operating modes can be switched using the menu button. If an operating mode is selected, the device sends the change to the bus three seconds after switching via the menu button.</p> <p>When inactive: The operating modes cannot be switched using the menu button.</p>	

Configuration objects	FanCoil: HVAC mode (DPT 20.102) SplitUnit: HVAC modes (DPT 20.105) SplitUnit: 1-bit objects
This parameter defines the data format of the objects for the operating mode switchover.	
Automatic mode	Active Inactive
<p>This parameter determines whether the "Automatic" operating mode is integrated into the switchover sequence at the press of a button.</p> <p>When active: The "Automatic" operating mode can be called up by switching via the menu button on the device. The "Automatic" operating mode can be called up via the communication object and shown as a status on the display.</p> <p>When inactive: The "Automatic" operating mode cannot be called up by switching via the menu button on the device. The "Automatic" operating mode can be called up via the communication object and shown as a status on the display.</p> <p>This parameter is visible if the "Configuration objects" parameter is set to "SplitUnit: ...".</p>	
Heating	Active Inactive
<p>This parameter determines whether the "Heating" operating mode is integrated into the switchover sequence at the press of a button.</p> <p>When active: The "Heating" operating mode can be called up by switching via the menu button on the device. The "Heating" operating mode can be called up via the communication object and shown as a status on the display.</p> <p>When inactive: The "Heating" operating mode cannot be called up by switching via the menu button on the device. The "Heating" operating mode can be called up via the communication object and shown as a status on the display.</p> <p>This parameter is visible if the "Configuration objects" parameter is set to "SplitUnit: ...".</p>	
Cooling	Active Inactive
<p>This parameter determines whether the "Cooling" operating mode is integrated into the switchover sequence at the press of a button.</p> <p>When active: The "Cooling" operating mode can be called up by switching via the menu button on the device. The "Cooling" operating mode can be called up via the communication object and shown as a status on the display.</p> <p>When inactive: The "Cooling" operating mode cannot be called up by switching via the menu button on the device. The "Cooling" operating mode can be called up via the communication object and shown as a status on the display.</p> <p>This parameter is visible if the "Configuration objects" parameter is set to "SplitUnit: ...".</p>	

Ventilating	Active Inactive
<p>This parameter determines whether the "Ventilation" operating mode is integrated into the switchover sequence at the press of a button.</p> <p>When active: The "Ventilation" operating mode can be called up by switching via the menu button on the device. The "Ventilate" operating mode can be called up via the communication object and shown as a status on the display.</p> <p>When inactive: The "Ventilation" operating mode cannot be called up by switching via the menu button on the device. The "Ventilate" operating mode can be called up via the communication object and shown as a status on the display.</p> <p>This parameter is visible if the "Configuration objects" parameter is set to "SplitUnit: ...".</p>	
Dehumidify	Active Inactive
<p>This parameter determines whether the "Dehumidify" operating mode is integrated into the switchover sequence at the press of a button.</p> <p>When active: The "Dehumidify" operating mode can be called up by switching via the menu button on the device. The "Dehumidify" operating mode can be called up via the communication object and shown as a status on the display.</p> <p>When inactive: The "Dehumidify" operating mode cannot be called up by switching via the menu button on the device. The "Dehumidify" operating mode can be called up via the communication object and shown as a status on the display.</p> <p>This parameter is visible if the "Configuration objects" parameter is set to "SplitUnit: ...".</p>	
Eco	Active Inactive
<p>This parameter determines whether the "Ventilation" operating mode is integrated into the switchover sequence at the press of a button.</p> <p>When active: The "Eco" operating mode can be selected via the menu button on the device. The "Ventilate" operating mode can be called up via the communication object and shown as a status on the display.</p> <p>When inactive: The "Eco" operating mode cannot be called up by switching via the menu button on the device. The "Ventilate" operating mode can be called up via the communication object and shown as a status on the display.</p> <p>This parameter is visible if the "Configuration objects" parameter is set to "SplitUnit: ...".</p>	

Boost	Active Inactive
<p>This parameter determines whether the "Boost" operating mode is integrated into the switchover sequence at the press of a button.</p> <p>When active: The "Boost" operating mode can be selected via the menu button on the device. The "Boost" operating mode can be called up via the communication object and shown as a status on the display.</p> <p>When inactive: The "Boost" operating mode cannot be called up by switching via the menu button on the device. The "Boost" operating mode can be called up via the communication object and shown as a status on the display.</p> <p>This parameter is visible if the "Configuration objects" parameter is set to "SplitUnit: ...".</p>	
Switch-over behaviour	Comfort / Standby / Night Comfort/Standby Comfort/Night Standby/Night
<p>This parameter changes the behaviour of the operating modes via the menu button. The device switches through the operating modes in sequence according to the selected values.</p> <p>This parameter is visible if the "Configuration objects" parameter is set to "Fan coil: HVAC mode (DPT 20.102)".</p>	
Extended parameters	Active Inactive
<p>This parameter enables extended configuration options for the operating mode switchover function for a fan coil unit.</p> <p>If the extended parameters are deactivated, the display does not show any additional symbols.</p> <p>When the advanced parameters are activated, the ETS shows the following parameters.</p>	
Additionally display eco symbol in standby/night mode	Active Inactive
<p>An additional eco symbol is shown on the display during operation if the controller is operating in standby or night operating mode.</p>	
Heating/cooling process indicated by symbol	Active Inactive
<p>An additional symbol is shown on the display during operation if the controller is actively heating or cooling.</p>	

Enable boost function	Active Inactive
This parameter enables the boost function.	

12.5 Air conditioning / split unit objects

Function	Name	Type	DPT	Flag
Setpoint temperature - Active operating mode	Display - Input	2-byte	9,001	C, -, W, T, U
2-byte object for external specification of the basic setpoint temperature. The controller rounds the temperature values received via the object to 0.1 K. The temperature value must always be specified in the format "°C".				

Function	Name	Type	DPT	Flag
Setpoint temperature specification	Display - Output	2-byte	9,001	C, R, -, T, A
2-byte object for specification of the setpoint temperature. The temperature value is specified in the format "°C".				

Function	Name	Type	DPT	Flag
Setpoint temperature - Shift	Display - Output	2-byte	9,002	C, R, -, T, A
2-byte object for presetting a basic setpoint shift. The value of a counter value in the communication object is 0.5 Kelvin. The value "0" means that no shift is active. The value is depicted in a double complement in the positive and negative direction.				

Function	Name	Type	DPT	Flag
Setpoint temperature - Shift status	Display - Input	2-byte	9,002	C, -, W, T, U
2-byte object used to feed back the current basic setpoint shift from the main controller. The value "0" means that no shift is active. The value is depicted in a double complement in the positive and negative direction.				

Function	Name	Type	DPT	Flag
Setpoint temperature shift	Display - Output	1-byte	6,010	C, R, -, T, A
1-byte object for presetting a basic setpoint shift. The value of a counter value in the communication object is 0.5 Kelvin. The value "0" means that no shift is active. The value is depicted in a double complement in the positive and negative direction.				

Function	Name	Type	DPT	Flag
Setpoint temperature shift status	Display - Input	1-byte	6,010	C, -, W, T, U
1-byte object used to feed back the current basic setpoint shift from the main controller. The value of a counter value in the communication object is 0.5 Kelvin. The value "0" means that no shift is active. The value is depicted in a double complement in the positive and negative direction.				

Function	Name	Type	DPT	Flag
Boost - Activate / Deactivate	Display - Output	1-bit	1,010	C, R, -, T, A
1-bit output object for requirement-orientated activation and deactivation of the boost function. The telegram polarity is fixed: "0" = boost inactive, "1" = boost active.				

Function	Name	Type	DPT	Flag
Boost - Status	Display - Input	1-bit	1,011	C, -, W, T, U
1-bit object via which the controller main unit outputs the current status of the boost function to the device. When the boost function is activated, the status object is set to the value "1". When the boost function is deactivated, the status object is set to the value "0".				

Function	Name	Type	DPT	Flag
Split unit - operating mode	Display - Output	1-byte	20,105	C, R, -, T, A
1-byte object for transmitting the operating mode set via the control surfaces of the device to the bus. If an operating mode is selected, the device sends the change to the bus three seconds after switching via the menu button.				

Function	Name	Type	DPT	Flag
Split unit - operating mode status	Display - Input	1-byte	20,105	C, -, W, T, U
1-byte object for receiving the operating mode set by the controller main unit and signalled on the bus.				

Function	Name	Type	DPT	Flag
Split Unit - Automatic	Display - Output	1-bit	1,002	C, R, -, T, A
1-bit object for transmitting the operating mode set via the control surfaces of the device to the bus. If an operating mode is selected, the device sends the change to the bus three seconds after switching via the menu button.				

Function	Name	Type	DPT	Flag
Split unit - Automatic status	Display - Input	1-bit	1,002	C, -, W, T, U
1-bit object for receiving the operating mode set by the controller main unit and signalled on the bus.				

Function	Name	Type	DPT	Flag
Split unit - heating	Display - Output	1-bit	1,002	C, R, -, T, A
1-bit object for transmitting the operating mode set via the control surfaces of the device to the bus. If an operating mode is selected, the device sends the change to the bus three seconds after switching via the menu button.				

Function	Name	Type	DPT	Flag
Split unit - Heating status	Display - Input	1-bit	1,002	C, -, W, T, U
1-bit object for receiving the operating mode set by the controller main unit and signalled on the bus.				

Function	Name	Type	DPT	Flag
Split unit - cooling	Display - Output	1-bit	1,002	C, R, -, T, A
1-bit object for transmitting the operating mode set via the control surfaces of the device to the bus. If an operating mode is selected, the device sends the change to the bus three seconds after switching via the menu button.				

Function	Name	Type	DPT	Flag
Split unit - Cooling status	Display - Input	1-bit	1,002	C, -, W, T, U
1-bit object for receiving the operating mode set by the controller main unit and signalled on the bus.				

Function	Name	Type	DPT	Flag
Split unit - Ventilation	Display - Output	1-bit	1,002	C, R, -, T, A
1-bit object for transmitting the operating mode set via the control surfaces of the device to the bus. If an operating mode is selected, the device sends the change to the bus three seconds after switching via the menu button.				

Function	Name	Type	DPT	Flag
Split unit - Ventilation status	Display - Input	1-bit	1,002	C, -, W, T, U
1-bit object for receiving the operating mode set by the controller main unit and signalled on the bus.				

Function	Name	Type	DPT	Flag
Split unit - Dehumidification	Display - Output	1-bit	1,002	C, R, -, T, A
<p>1-bit object for transmitting the operating mode set via the control surfaces of the device to the bus.</p> <p>If an operating mode is selected, the device sends the change to the bus three seconds after switching via the menu button.</p>				
Function	Name	Type	DPT	Flag
Split unit - Dehumidification status	Display - Input	1-bit	1,002	C, -, W, T, U
<p>1-bit object for receiving the operating mode set by the controller main unit and signalled on the bus.</p>				
Function	Name	Type	DPT	Flag
Split unit - ECO	Display - Output	1-bit	1,002	C, R, -, T, A
<p>1-bit object for transmitting the operating mode set via the control surfaces of the device to the bus.</p> <p>If an operating mode is selected, the device sends the change to the bus three seconds after switching via the menu button.</p>				
Function	Name	Type	DPT	Flag
Split unit - ECO status	Display - Input	1-bit	1,002	C, -, W, T, U
<p>1-bit object for receiving the operating mode set by the controller main unit and signalled on the bus.</p>				
Function	Name	Type	DPT	Flag
Split Unit - Boost	Display - Output	1-bit	1,002	C, R, -, T, A
<p>1-bit object for transmitting the operating mode set via the control surfaces of the device to the bus.</p> <p>If an operating mode is selected, the device sends the change to the bus three seconds after switching via the menu button.</p>				
Function	Name	Type	DPT	Flag
Split unit - Boost status	Display - Input	1-bit	1,002	C, -, W, T, U
<p>1-bit object for receiving the operating mode set by the controller main unit and signalled on the bus.</p>				
Function	Name	Type	DPT	Flag
Split unit - operating mode	Display - Output	1-byte	20,102	C, R, -, T, A
<p>1-byte object for transmitting the operating mode set via the control surfaces of the device to the bus.</p> <p>If an operating mode is selected, the device sends the change to the bus three seconds after switching via the menu button.</p>				

Function	Name	Type	DPT	Flag
Split unit - operating mode status	Display - Input	1-byte	20,102	C, -, W, T, U
1-byte object for receiving the operating mode set by the controller main unit and signalled on the bus.				

Function	Name	Type	DPT	Flag
Heating status indication	Display - Input	1-bit	1,001	C, -, W, T, U
A main controller can usually signal via a separate object whether the controller is currently requesting heating energy and is therefore actively heating. The device can receive the message for active heating from the controller main unit via this object. The device shows the heating symbol on the display as soon as heating is active.				

Function	Name	Type	DPT	Flag
Cooling status indication	Display - Input	1-bit	1,001	C, -, W, T, U
A main controller can usually signal via a separate object whether the controller is currently requesting cooling energy and is therefore actively cooling. The device can receive the message for active cooling from the controller main unit via this object. The device shows the cooling symbol on the display as soon as cooling is active.				

Function	Name	Type	DPT	Flag
Specification, ventilation, automatic/manual	Display - Output	1-bit	1,001	C, R, -, T, A
1-bit object for transmitting a telegram for switching between automatic mode and manual operation of the ventilation at the controller main unit. The object polarity can be configured.				

Function	Name	Type	DPT	Flag
Status Ventilation Auto/Manual	Display - Input	1-bit	1,001	C, -, W, T, U
1-bit object for receiving the "Automatic operation" or "Manual operation" status telegram of the ventilation at the controller main unit. The object polarity can be configured.				

Function	Name	Type	DPT	Flag
Fan level specification	Display - Output	1-byte	5,100	C, R, -, T, A
1-byte object for transmitting the fan speed set via the control surfaces of the device to the bus. Value range: 0 ... max. 5. The maximum value is limited by the number of configured fan levels. If one is selected, the device sends the change to the bus three seconds after switching via the menu button.				

Function	Name	Type	DPT	Flag
Status Fan level Set-point	Display - Input	1-byte	5,100	C, -, W, T, U
1-byte object for receiving the feedback of the current fan speed from the controller main unit.				

Function	Name	Type	DPT	Flag
Fan level specification	Display - Output	1-byte	5,001	C, R, -, T, A
1-byte object for transmitting the fan speed set via the control surfaces of the device to the bus.				
Value range: 0 ... 100%. The device converts the percentage into fan levels. Where 0% = fan off, 1% ... = fan speed 1 and 100% = highest fan speed.				
Depending on the configured number of fan levels, there is a proportional assignment between the percentage and the fan level .				
After the switchover, the device sends the change to the bus three seconds after the switchover via the menu button.				

Function	Name	Type	DPT	Flag
Status Fan level Set-point	Display - Input	1-byte	5,001	C, -, W, T, U
1-byte object used to receive feedback on the active manual fan speed. Because the device works only with fan levels in manual mode, the highest percentage of the currently active fan level is displayed as the status.				

13 Display

The device has a display (see chapter "Front view" ▶ Page 6).

The display contains various segments that can be used to show different information (see chapter "Icons in the display" ▶ Page 9).

The brightness of the display is adjustable







Figure 36: Icons in the display

13.1 Display indicators

Operating mode indication

The device can show the currently active operating mode in the top right of the indicator if this display is activated in the ETS on the "Fan coil with controller -> Heating control -> General" parameter page or on the "Air conditioning/split unit" parameter page.

The following operating modes can be shown on the display:

-  Comfort operating mode is active
-  Reduction temperature operating mode is active
-  Night setback operating mode is active
-  Eco operating mode is active

Main display and secondary display

The display is divided into a main display and a secondary display, corresponding to the red frames.



Figure 37: Main display of the display



Figure 38: Secondary display of the display

The main display can show the actual temperature or the set temperature in large letters in the centre of the display.

If the main display shows the current actual temperature according to the parametrisation, the secondary display simultaneously shows the set target temperature.

If the main display shows the setpoint temperature, you can set in the ETS whether the secondary display shows the actual temperature in small form in the right-hand display area or whether no temperature is shown at this point in the display.

- i** The temperature is displayed in the secondary segment in 0.5 °C increments. The display shows rounding values when the temperature is changed via the bus in 0.1 °C increments.

Humidity display

A humidity value in per cent can be shown in the secondary display if this indicator is activated in the ETS on the "Display -> Display settings" parameter page. In this case, a drop symbol in the main display indicates that the secondary display is showing the humidity value.



Humidity (only for "Comfort" variant)

- i** The humidity value is shown in the secondary display in automatic alternation with the actual or target temperature for 5 seconds if the secondary display is to show one of these temperatures.
- i** When the operating lock is active, the drop symbol of the humidity display is not shown in the main display because the lock symbol is shown with higher priority.
- i** If the display is inactive and the display is activated for the first time using the menu button, this has no effect on the alternating display of temperature and humidity values.

- i** If the operating modes are changed using the menu button, the change to the humidity display is suspended during operation and then for 10 seconds in the secondary display.
- i** If the setpoint temperature is shown and changed in the secondary display, the change to the humidity display is suspended during operation and then for 10 seconds in the secondary display.

Indication in switched-off state

The secondary display shows "OFF" when the device is switched off.

In the ETS, parameters can be used to select whether the actual temperature should also be displayed in the main segment (see chapter "On/off function" ▶ Page 42).

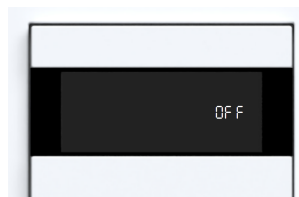

Figure 39: Display in switched-off state

Window status display

The device can show an open window in the centre-left display area if this indicator is activated in the ETS on the "Display -> Display settings" parameter page. By activating the "Show warning message" parameter under Window status when window is open, the ETS offers the "Window contact - default" communication object, which can be used to show or hide the "open window" symbol in the display.



Window status (open window was recognised)

In addition, operation can be blocked on the device when the window is open. If a window is signalled as open, operation of the control surfaces of the appliance is blocked. Any operations are not analysed and processed. The device signals that operation is blocked when the window is open by flashing the window symbol. At the same time, the display brightness changes to the value "During operation" for 20 seconds.

Show operating lock

The device can show a lock symbol in the main display if the operating lock is activated in the ETS on the "General" parameter page and the operating lock is active. When the operating lock is activated, the device shows the lock symbol in the main display when locked (see chapter "Operating lock" ▶ Page 39).



Operating lock is activated

If the operating element of the appliance is touched when the operating lock is switched on, the lock symbol flashes. This shows that the device is locked. At the same time, the display brightness changes to the value "During operation" for 20 seconds.

-  When the operating lock is active, the drop symbol of the humidity display is not shown in the main display because the lock symbol is shown with higher priority.

Display boost function

While the boost function is switched on, the display shows a rocket symbol in the top left-hand display area Boost function.



The boost function is active

Indicating heating and cooling

For the "Heating" or "Cooling" duration, the display shows the corresponding symbol in the bottom right-hand display area Controller status.



Heating/cooling

Indicating the fan control

The display shows the ventilation control in the right-hand display area.

In manual mode, the display shows the symbol "Ventilation operating mode is active". Depending on the fan level set, 1 to 5 horizontal bars are displayed above the symbol.

In automatic mode, the display shows the "Ventilation in automatic mode" symbol.



Ventilation operating mode is active

The bars above the symbol indicate the ventilation level



Ventilation in automatic mode

-  As soon as the status of the fan level is received as "Off", the display does not show a fan control symbol.

Indicating automatic operation

The display shows the symbol for automatic mode in the right-hand display area.



Automatic mode is active.

Display ventilation and dehumidification

The display shows the symbols for ventilation and dehumidification in the right-hand display area.



Ventilation/dehumidification (only for "Comfort" variant as "Split unit control" device type)

13.1.1 Table of parameters

Parameter page "Display -> Display settings"

Main display	Actual-temperature Setpoint temperature
<p>This parameter defines which temperature value is shown on the main display. The setting of this parameter influences the parameterisability of the "Secondary display" parameter.</p> <p>For "Actual temperature": The main display shows the actual temperature. The secondary indication of the display indicates the setpoint temperature.</p> <p>For "Set temperature": The main display shows the set temperature. The secondary display can be parameterised.</p>	
Secondary display	Actual-temperature no temperature
<p>This parameter defines whether the actual temperature is shown on the secondary display or whether the secondary display does not show any temperature. The availability of this parameter depends on the parameterisation of the "Main display" parameter.</p> <p>For "Actual temperature": The secondary display shows the actual temperature. With "no temperature": The secondary display does not show any temperature.</p> <p>i The temperature is displayed in the secondary segment in 0.5 °C increments. The display shows rounding values when the temperature is changed via the bus in 0.1 °C increments.</p>	
Indication of actual temperature	internal sensor external value via bus
<p>The source for displaying the actual temperature can either be the internal sensor in the device or an external value received via the bus.</p> <p>i For the display of the actual temperature from the internal sensor to work, the temperature measurement of the device must first be activated and parameterised.</p> <p>With "internal sensor": The display shows the actual temperature of the device's internal temperature measurement, including weighting of the measured values if necessary. The value corresponds to the value of the "Room temperature - Actual temperature - Status" communication object.</p> <p>With "external value via bus": The display shows the temperature value "Actual temperature display (external sensor)" received via the communication object.</p>	

Display humidity value (%)	Active Inactive
The display will show a humidity value in per cent in the secondary display if this indicator is activated. In this case, a drop symbol in the main display indicates that the secondary display is showing the humidity value.	
Display warning message	Active Inactive
The device shows an open window in the centre left of the display when this indicator is activated. By activating the "Show warning message" parameter, the ETS offers the "Window contact - default" communication object, which can be used to show or hide the "open window" symbol in the display.	
Disable operation	Active Inactive
In addition, operation can be blocked on the device when the window is open. If a window is signalled as open, operation of the control surfaces of the appliance is blocked. Any operations are not analysed and processed. The device signals that operation is blocked when the window is open by flashing the window symbol. At the same time, the display brightness changes to the value "During operation" for 20 seconds.	

13.1.2 Object list

Function	Name	Type	DPT	Flag
Window contact - default	Display - Input	1-bit	1,019	C, -, W, T, U
<p>1-bit object for specifying and evaluating a window contact.</p> <p>The received value "1 = Open" or "0 = Closed" specifies whether the "open window" symbol is shown or hidden in the display.</p> <p>The object is offered in the ETS when the "Display warning message" parameter is activated under Window status when window is open.</p> <p>In addition, operation can be blocked on the device when the window is open. If a window is signalled as open, operation of the control surfaces of the appliance is blocked. Any operations are not analysed and processed.</p>				
Function	Name	Type	DPT	Flag
Operating lock - Status	Display - Output	1-bit	1,003	C, R, -, T, A
<p>1-bit object for outputting the current status of the operating lock (0 = operating lock switched off / 1 = operating lock switched on).</p>				
Function	Name	Type	DPT	Flag
Operating lock - default	Display - Input	1-bit	1,003	C, -, W, T, U
<p>1-bit object for switching the operating lock on and off via object (0 = switch off operating lock / 1 = switch on operating lock).</p>				

Function	Name	Type	DPT	Flag
External humidity (external sensor)	Display - Input	2-byte	9,007	C, -, W, T, U

2-byte object for coupling an external KNX humidity sensor or a controller extension. This enables cascading of several humidity sensors for humidity measurement. The temperature value must always be specified in the format "%".

Function	Name	Type	DPT	Flag
Actual temperature display (external sensor)	Display - Input	2-byte	9,001	C, -, W, T, U

2-byte object used to connect an external KNX room temperature sensor or a controller extension unit for indication on the display. The temperature value must always be specified in the format "°C".

13.2 Display brightness

The brightness of the display is adjustable. Up to four brightness values for a day and night mode can be parameterised for the display in the ETS.

The display can operate in a continuous mode with one brightness value "During operation" and one brightness value "In idle state" or it can optionally operate in a day and night mode, each with two different brightness values for "During operation" and "In idle state". Switching between day and night mode takes place via an object, whereby the object polarity can be parameterised.

The brightness is set in the ETS via 10 levels. Each level corresponds to a brightness level stored in the device as a percentage.

Brightness level in the ETS	Brightness of the display
1	2 per cent
2	20 per cent
3	30 per cent
4	40 per cent
5	50 per cent
6	60 per cent
7	70 per cent
8	80 per cent
9	90 per cent
10	100 per cent

The brightness can be set during operation via a communication object. After enabling via the "Brightness setting via object" parameter, a brightness value of 0 to 100 per cent can be specified for the display via the "Brightness" communication object via the bus.

- i** If brightness values of less than 10 per cent are received via the bus, the device sets the brightness of the display to brightness level 1 = 2 per cent.

The display brightness after bus voltage return can be set in the parameters. The brightness settings via the communication object remain stored in the device in the event of a power failure, for example, and can be set again automatically by the device after bus voltage return.

After an ETS programming operation, the device sets the brightness levels defined in the parameters for the various modes and statuses.

13.2.1 Table of parameters

Parameter page "Display -> Display settings"

Day and night mode	Active Inactive
<p>With "Active": The display operates in a day and night mode, each with two different brightness values for "During operation" and "In idle state".</p> <p>With "Inactive": The display operates in a continuous mode with a brightness value "During operation" and a brightness value "In idle state".</p> <p>Switching between day and night mode takes place via an object, whereby the object polarity can be parameterised.</p>	
During operation	1...7...10
<p>This parameter defines the brightness of the display in continuous mode and during operation. The brightness remains set for 20 seconds after the last operation.</p> <p>The brightness is set in the ETS via 10 levels. Each level corresponds to a brightness level stored in the device as a percentage (1 = 2 %, 2 = 20 %, 3 = 30 %, 4 = 40%, 5 = 50 %, 6 = 60 %, 7 = 70%, 8 = 80 %, 9 = 90 %, 10 = 100 %).</p>	
In idle state	1...3...10
<p>This parameter defines the brightness of the display in continuous mode and in idle mode, which is activated by the device 20 seconds after the last operation.</p> <p>The brightness is set in the ETS via 10 levels. Each level corresponds to a brightness level stored in the device as a percentage (1 = 2 %, 2 = 20 %, 3 = 30 %, 4 = 40%, 5 = 50 %, 6 = 60 %, 7 = 70%, 8 = 80 %, 9 = 90 %, 10 = 100 %).</p>	
During operation, by day	1...7...10
<p>This parameter defines the brightness of the display in day and night mode, during the day and during operation. The brightness remains set for 20 seconds after the last operation.</p> <p>The brightness is set in the ETS via 10 levels. Each level corresponds to a brightness level stored in the device as a percentage (1 = 2 %, 2 = 20 %, 3 = 30 %, 4 = 40%, 5 = 50 %, 6 = 60 %, 7 = 70%, 8 = 80 %, 9 = 90 %, 10 = 100 %).</p>	
During operation, at night	1...4...10
<p>This parameter defines the brightness of the display in day and night mode, at night and during operation. The brightness remains set for 20 seconds after the last operation.</p> <p>The brightness is set in the ETS via 10 levels. Each level corresponds to a brightness level stored in the device as a percentage (1 = 2 %, 2 = 20 %, 3 = 30 %, 4 = 40%, 5 = 50 %, 6 = 60 %, 7 = 70%, 8 = 80 %, 9 = 90 %, 10 = 100 %).</p>	

In idle state, by day	1...3...10
<p>This parameter defines the brightness of the display in day and night mode, during the day and in idle mode, which is activated by the device 20 seconds after the last operation.</p> <p>The brightness is set in the ETS via 10 levels. Each level corresponds to a brightness level stored in the device as a percentage (1 = 2 %, 2 = 20 %, 3 = 30 %, 4 = 40%, 5 = 50 %, 6 = 60 %, 7 = 70%, 8 = 80 %, 9 = 90 %, 10 = 100 %).</p> <p>x</p>	
In idle state, at night	1...1...10
<p>This parameter defines the brightness of the display in day and night mode, at night and in idle mode, which is activated by the device 20 seconds after the last operation.</p> <p>The brightness is set in the ETS via 10 levels. Each level corresponds to a brightness level stored in the device as a percentage (1 = 2 %, 2 = 20 %, 3 = 30 %, 4 = 40%, 5 = 50 %, 6 = 60 %, 7 = 70%, 8 = 80 %, 9 = 90 %, 10 = 100 %).</p>	
Brightness setting via object	Active Inactive
<p>The brightness can be set during operation via a communication object. After enabling via this parameter, the display can be given a brightness value of 0 to 100 per cent via the bus using the "Brightness" communication object.</p> <p>i If brightness values of less than 10 per cent are received via the bus, the device sets the brightness of the display to brightness level 1 = 2 per cent.</p>	
After the bus voltage returns	State as before bus voltage failure Query current status No reaction
<p>The display brightness after bus voltage return is set by this parameter.</p> <p>With "Status as before bus voltage failure": The device sets the display to the same brightness as before the bus voltage failure.</p> <p>With "Query current status":</p> <p>"No reaction":</p>	
Object - Polarity	0 = day / 1 = night 1 = day / 0 = night
<p>This parameter defines the object polarity of the "Day and night mode" communication object.</p>	

13.2.2 Object list

Function	Name	Type	DPT	Flag
Day and night mode	Display - Input	1-bit	1,024	C, -, W, T, U
1-bit object for switching between day and night mode. The object polarity can be configured.				
Function	Name	Type	DPT	Flag
Brightness	Display - Input	1-byte	5,001	C, -, W, T, U
1-byte object for specifying the display brightness via object. Brightness values from 0 to 100 per cent can be specified via the bus.				
<p>i If brightness values of less than 10 per cent are received via the bus, the device sets the brightness of the display to brightness level 1 = 2 per cent.</p>				

14 Heartbeat function

The heartbeat function makes it easy to check whether the application is running error-free in a device. For this purpose, the communication object Heartbeat sends a corresponding heartbeat telegram with a settable cycle time. The heartbeat function is enabled on the "General" parameter page.

14.1 Parameters for heartbeat

General - Enabled functions

Heartbeat function	Checkbox (yes / no)
If the parameter is activated, the heartbeat functions and thus the "Heartbeat" object are enabled.	

General -> Heartbeat

Cycle time for transmission of device status	0 ... 23 h 0 ... 2 ... 59 min
This parameter defines the time with which the device sends a telegram with the value "1" when the application is running. To limit the bus load, times shorter than 1 minute are excluded.	

14.2 Object list for heartbeat

Function	Name	Type	DPT	Flag
Heartbeat	Device - Output	1-bit	1,002	C, R, -, T, A
1-bit object for cyclical signalling of the device function. When the application of the device is running, the communication object transmits the value "1" at the set cycle time.				

Gira
Giersiepen GmbH & Co. KG
Elektro-Installations-
Systeme

Industriegebiet Mermbach
Dahlienstraße
42477 Radevormwald

Postfach 12 20
42461 Radevormwald

Deutschland

Tel +49(0)21 95 - 602-0
Fax +49(0)21 95 - 602-191

www.gira.de
info@gira.de